



MR2 Series Motorized Trolley (125kg to 5t)

Parts List

Contents

Contents	2
Introduction	2
Frame and Wheel related	3
Suspension shaft related	3
Motor related	4
Gear related.....	4
Connection box related (Single speed type).....	5
Connection box related (Dual speed inverter (VFD) type).....	7
Connection box related (Dual speed, 500V class)	9
Push button related	11
Power supply cable and Accesory related/Trolley cable related.....	12

Introduction

Target products

Product code

The parts lists show the related parts for the MR2 Series Motorized Trolley. The types of the target products are as shown below. For the parts of the hoist, refer to ER2 Series Electric Chain Hoist Parts List.

Capacity	CODE		
	Single speed model		Dual speed model
	Standard speed	Low speed	Standard speed
125kg	MR2-010S	MR2-010L	MR2-010IS/SD
250kg			
500kg			
1t	MR2-020S	MR2-020L	MR2-020IS/SD
1.5t			
2t			
2.5t	MR2-030S	MR2-030L	MR2-030IS/SD
2.8t			
3t			
5t	MR2-050S	MR2-050L	MR2-050IS/SD

Product category and voltage

The product has four categories for power supply voltages.

Product category	Motor Insulation Class	Voltage range		Operating Voltage
		50Hz	60Hz	
230V Class	B	220V	220V	24V (24V to 26.4V)
		230V	230V	
400V Class	F	380V	380V	
		400V	440V	
		415V	-	
500V Class	B	500V	575V	
230/460V Class		208-230V	110V (110V to 120V)	
	415-460V			

Interpretation of parts lists

- Match the number in the 3D diagram with "In Diagram" in the parts list to obtain the part name.
- Cells with an x-mark at intersection of Part name and product code in the parts table are not used.
- Blank cells at the intersection of Part name and product code in the parts table vary the part number depending on the power supply voltage.
- For the cells with an arrow mark, the product code listed in the left cell should be applied. If you need a part for the blank cell, let us know the product code shown in the preceding item, power supply voltage and part number.

Push button cord complete set

When ordering a push button cord complete set, let us know the cord length referring to the following table.

Capacity	Push button cord length	
	Direct connection	Plug connection
125kg - 2.5t	same as Lift(m)	Lift(m)-0.2m
2.8t - 5t	Lift(m)+0.3m	Lift(m)+0.1m

How to order

- When ordering, let us know the product code, voltage, Part name, Part number and quantity.
- For part price and delivery date, contact our distributor or KITO.

Frame and Wheel related/Suspension shaft related

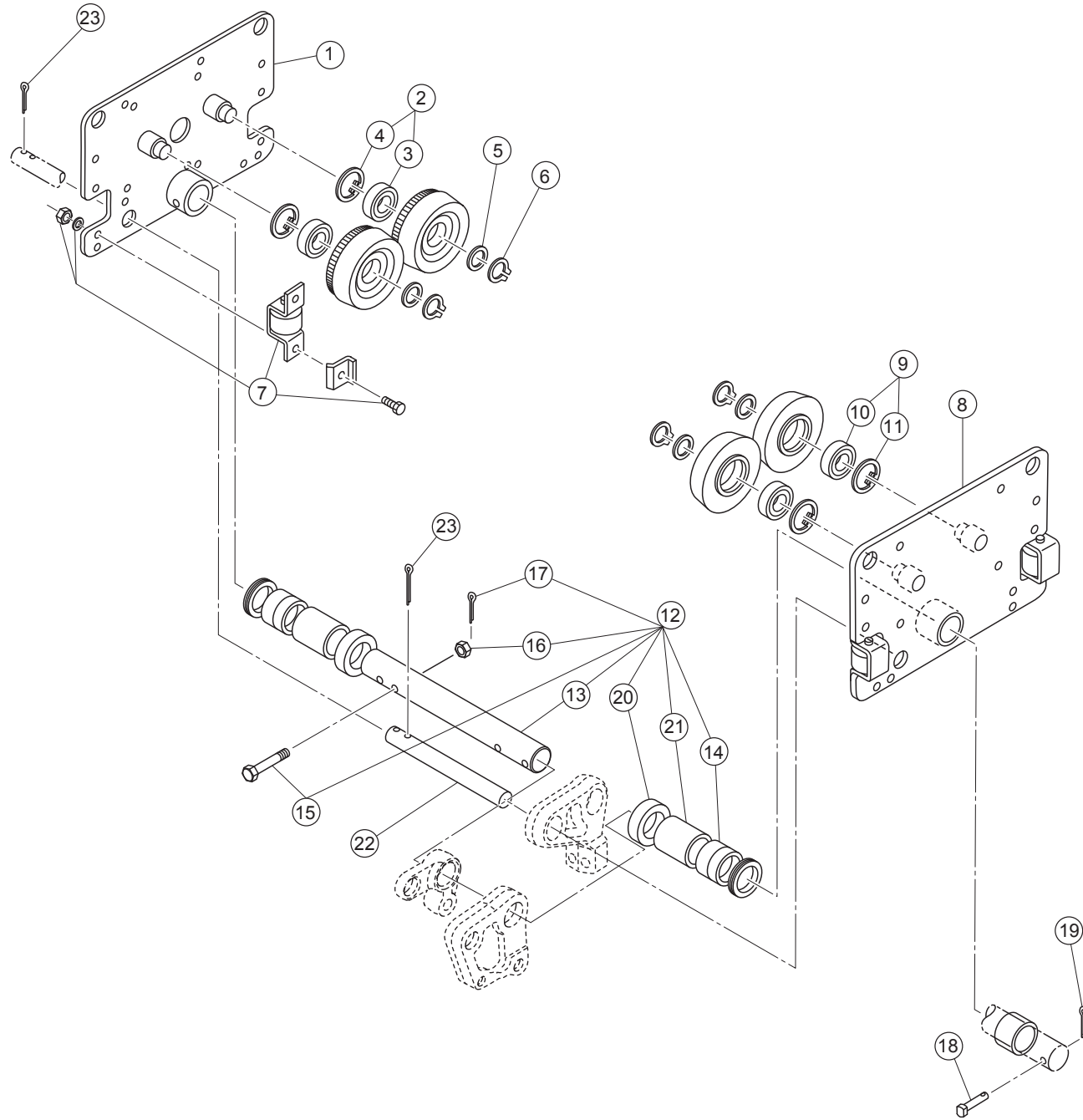

Frame and Wheel related/Suspension shaft related

Frame and Wheel related

In Diagram	Part Number	Part Name	Quantity per unit	Product code				Summary
				MR2-010S/L MR2-010IS/SD	MR2-020S/L MR2-020IS/SD	MR2-030S/L MR2-030IS/SD	MR2-050S/L MR2-050IS/SD	
1	5201	Side plate G assembly	1	MR1DS5201	MR1ES5201	MR1FS5201	MR1GS5201	
2	1231	Track wheel G assembly	2	M6SE010S1101	M6SE020S1101	M6SE030S1101	M7SE050S1101	
3	233	Ball bearing	2	J1GR020-06302	J1GR020-06304	J1GR020-06305	J1GR020-06307	
4	234	Snap ring	2	J1SR000-00042	J1SR000-00052	J1SR000-00062	J1SR000-00080	
5	235	Washer	2	T6GA010-9104	T1GA020-9104	T1GA030-9104	M6SE050S9104	For track wheel G
6	236	Snap ring	2	J1SS000-00015	J1SS000-00020	J1SS000-00025	J1SS000-00035	For track wheel G
7	1211	Side roller complete set	4	S.R SET 010	S.R SET 020	←	S.R SET 050	
8	5202	Side plate S assembly	1	MR1DS5202	MR1ES5202	MR1FS5202	MR1GS5202	
9	1232	Track wheel S assembly	2	M6SE010S1102	M6SE020S1102	M6SE030S1102	M7SE050S1102	
10	233	Ball bearing	2	J1GR0B0-06302	J1GR020-06304	J1GR0B0-06305	J1GR0B0-06307	
11	234	Snap ring	2	J1SR000-00042	J1SR000-00052	J1SR000-00062	J1SR000-00080	

Suspension shaft related

In Diagram	Part Number	Part Name	MR2-010S/L/IS/SD		MR2-020S/L/IS/SD		MR2-030S/L/IS/SD		MR2-050S/L/IS/SD		Summary
			Quantity per unit		Quantity per unit		Quantity per unit		Quantity per unit		
12	2101	Suspension shaft complete set (125,150,175)	1	MR1DS2111	1	MR1ES2111	1	MR1FS2111	1	MR1GS1111	
13	101	Suspension shaft (125,150,175)	1	M7SE010S9115	1	M7SE020S9115	1	MR1FS9101	1	MR1GS9101	
14	102	Thick spacer	5	T4GA010-9116	5	T7GA030-9116	5	T4GA030-9116	3	T1GA050-9116	
15	103	Bolt	1	T1GA010-9153	1	M6FE020S9161	1	T1GA030-9153	1	M6SE050S9161	
16	104	Slotted nut	1	J1NL002-10100	1	J1NL002-10100	1	J1NL002-20120	1	J1NL002-20120	
17	105	Split pin	1	J1PW01-025018	1	J1PW01-025018	1	J1PW01-030022	1	J1PW01-030022	
18	106	Shaft stopper	1	T6GA020-9156	1	M6FE020S9164	1	M6SE030S9164	1	M6SE050S9164	
19	107	Split pin	1	J1PW02-040020	1	J1PW02-040020	1	J1PW02-040022	1	J1PW02-040022	
20	110	Thick spacer L	2	MR1DS9110	2	MR1ES9110	2	MR1FS9110	2	MR1GS9110	
12	1121	Suspension shaft complete set (300)	1	MR1DS1112	1	MR1ES1112	1	MR1FS1112	1	MR1GS1112	
13	101	Suspension shaft (300)	1	M7SE010S9181	1	M7SE020S9181	1	MR1FS9121	1	MR1GS9121	
14	102	Thick spacer	9	T4GA010-9116	9	T7GA030-9116	9	T4GA030-9116	13	T1GA050-9116	
15	103	Bolt	1	T1GA010-9153	1	M6FE020S9161	1	T1GA030-9153	1	M6SE050S9161	
16	104	Slotted nut	1	J1NL002-10100	1	J1NL002-10100	1	J1NL002-20120	1	J1NL002-20120	
17	105	Split pin	1	J1PW01-025018	1	J1PW01-025018	1	J1PW01-030022	1	J1PW01-030022	
18	106	Shaft stopper	1	T6GA020-9156	1	M6FE020S9164	1	M6SE030S9164	1	M6SE050S9164	
19	107	Split pin	1	J1PW02-040020	1	J1PW02-040020	1	J1PW02-040022	1	J1PW02-040022	
20	110	Thick spacer L	2	MR1DS9110	2	MR1ES9110	2	MR1FS9110	2	MR1GS9110	
21	108	Fixing spacer (300)	2	M7SE010S9182	2	M7SE020S9182	2	M7SE030S9182	-	x	
22	131	Fixing shaft	1	MR1DS9131	1	MR1ES9131	1	MR1FS9131	1	MR1GS9131	For standerd beam
	141	Fixing shaft	1	MR1DS9141	1	MR1ES9141	1	MR1FS9141	1	MR1GS9141	For wide beam
23	132	Split pin	2	J1PW02-050040	2	J1PW02-050040	2	J1PW02-050050	2	J1PW02-050050	For fixing shaft

Motor related/Gear related

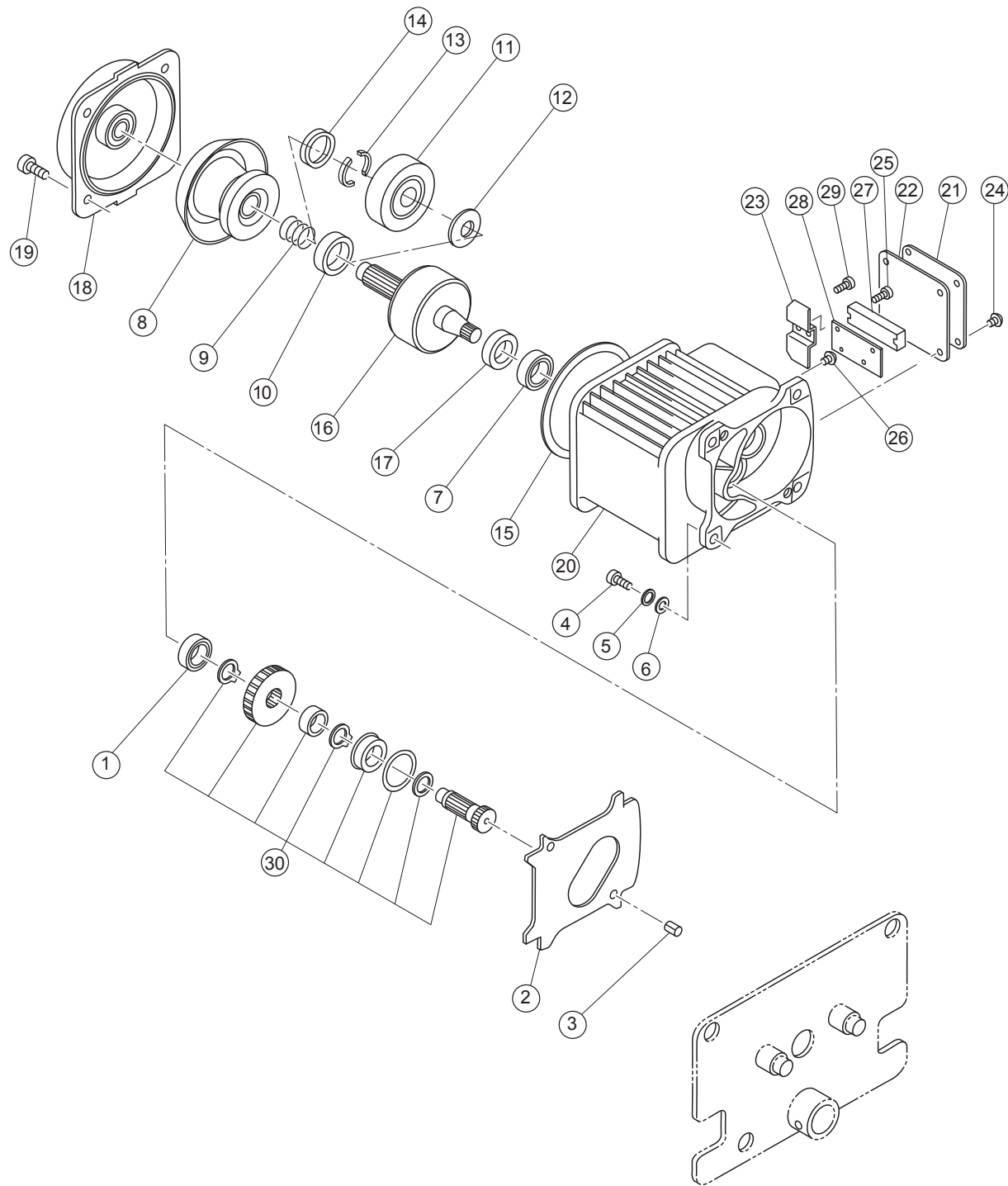

Motor related/Gear related

Motor related

In Diagram	Part Number	Part Name	Quantity per unit	Product code		Summary
				MR2-010S/L/IS/SD MR2-020S/L/IS/SD MR2-030S/L/IS/SD	MR2-050S/L/IS/SD	
1	247	Ball bearing	1	J1GR020-06002	J1GR020-06002	For gear #3 on gear frame side
2	248	Gear frame packing	1	MR1DS9248	MR1DS9248	
3	249	Set pin	2	MR1DS9249	MR1DS9249	For gear frame and frame G
4	250	Bolt	4	J1BA1-0802525	J1BA1-0802525	For gear frame. Integrated type with spring/flat washer is available. (251 and 252 are not necessary.)
5	251	Spring lock washer	4	J1WS011-20080	J1WS011-20080	For gear frame
6	252	Washer	4	J1WA011-00080	J1WA011-00080	For gear frame
7	253	Ball bearing	1	J1GR0C0-06204	J1GR0C0-06204	For gear frame on motor side
8	5261	Brake drum assembly	1	MR1DS5261 MR1DB5261	MR1DS5261 MR1DB5261	For 500V class dual speed
9	264	Brake spring	1	M3ES010-9304 MR1DB9264	M3ES010-9304 MR1DB9264	For 500V class dual speed
10	265	Bumper	1	MR1DS9265	MR1DS9265	For single speed
11	271	Pull rotor	1	E5FE005S9503	E5FE005S9503	For 500V class dual speed
12	272	Coned disc spring	1	E5FE005S9504	E5FE005S9504	For 500V class dual speed
13	273	Thrust disc	2	E5FE005S9505	E5FE005S9505	For 500V class dual speed
14	274	Thrust collar	1	E5FE005S9506	E5FE005S9506	For 500V class dual speed
15	281	Guard	1	MR1DS9281	MR1DS9281	
16	5291	Motor shaft with rotor	1	MR1DS5291 MR1DB5291 MR1FB5291	MR1GS5291 MR1FB5291 —	For 500V class dual speed 030SD, For 500V class dual speed
17	293	Oil seal	1	MR1DS9293	MR1DS9293	
18	1301	Motor cover assembly	1	MR1DS1301	MR1DS1301	
19	304	Socket bolt	4	J1BE1-0802222	J1BE1-0802222	For motor cover
20	5321	Motor frame with stator	1			*
21	324	Terminal cover	1	M6FE005S9206 MR1GS9324	M7SE010B92061 MR1GS9324	For 500V class dual speed
22	325	Terminal cover packing	1	MR1DS9325 MR1GS9325	MR1GS9325 MR1GS9325	For 500V class dual speed
23	326	Coil cover	1	MR1DS9326	MR1DS9326	
24	331	Machine screw with spring washer	4	J1AP2-5001010	J1AP2-5001010	For terminal cover
25	332	Machine screw with spring washer	2	J1AW2-4002020	←	For terminal plate
26	334	Machine screw with spring washer	1	J1AP2-4000808	J1AP2-4000808	For ground
27	851	Terminal 6P	1			*
28	855	Terminal plate holder	1	MR1DS9855	MR1DS9855	For 500V class, dual voltage
29	857	Flat head screw	2	J1AL2-4001010	J1AL2-4001010	For 500V class, terminal 6P

Gear related

In Diagram	Part Number	Part Name	Quantity per unit	Product code								Summary
				MR2-010S/IS	MR2-010L MR2-010SD	MR2-020S/IS	MR2-020L MR2-020SD	MR2-030S/IS	MR2-030L MR2-030SD	MR2-050S/IS	MR2-050L MR2-050SD	
30	1241	Gear complete set	1	MR1DS1241	MR1DL1241	MR1ES1241	MR1EL1241	MR1ES1241	MR1EL1241	MR1GS1241	MR1GL1241	

* The part codes vary depending on the power supply voltage.

Connection box related (Single speed type)

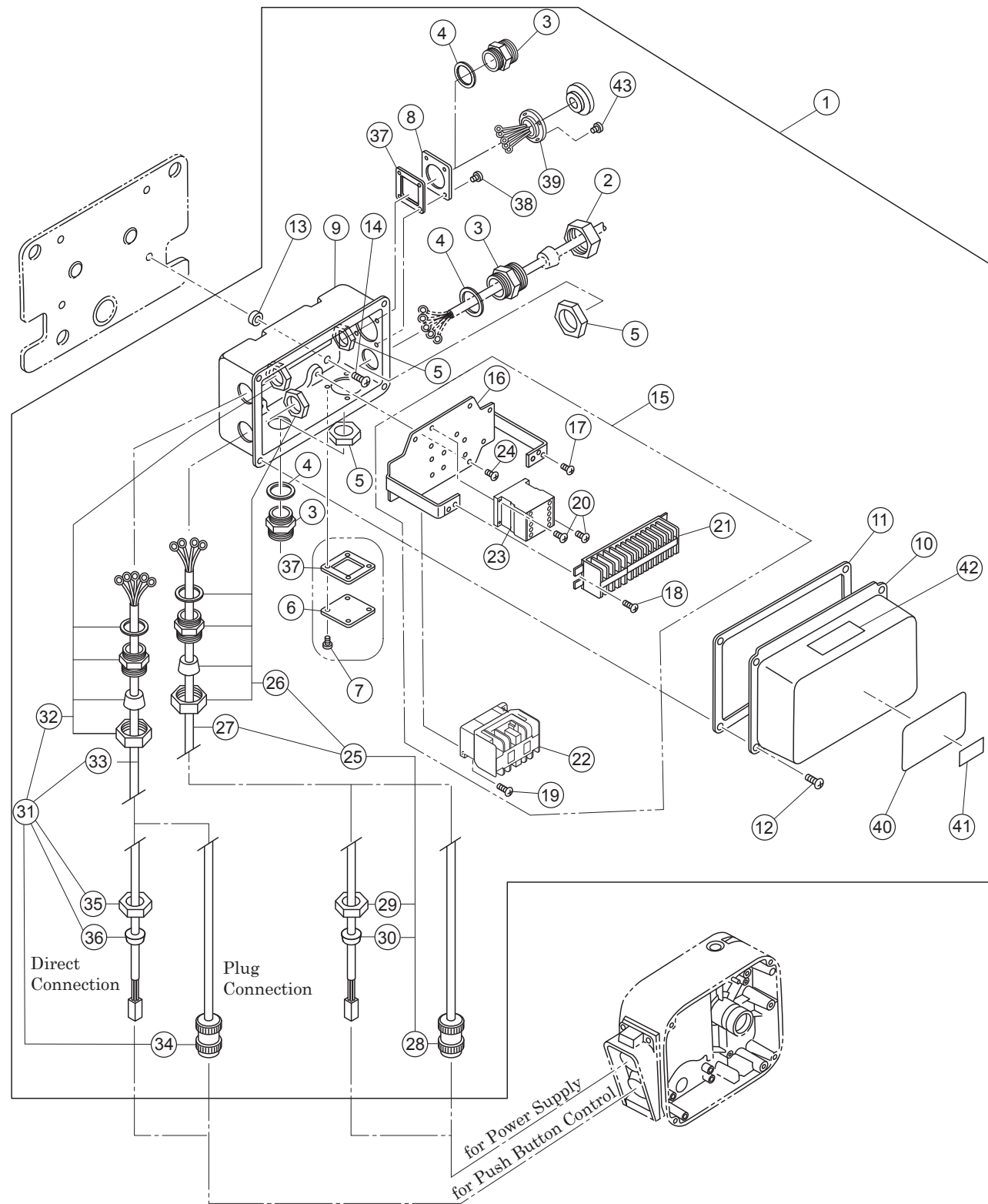

Connection box related (Single speed type)

In Diagram	Part Number	Part Name	Quantity per unit	Product code				Summary
				MR2-010S/L	MR2-020S/L	MR2-030S/L	MR2-050S/L	
1	1401	Connection box complete set	1					*
2	341	Holder A	1	ECP5924AA	←	←	←	
3	342	Holder B	2/3	ECP5924AB	←	←	←	Direct connection provides 3 pieces
4	343	Packing	2/3	ECP5924AC	←	←	←	Direct connection provides 3 pieces
5	344	Holder nut	2/3	ECP5924AD	←	←	←	Direct connection provides 3 pieces
6	347	Cord cover	1	E6LE010S9630	←	←	←	
7	348	Machine screw with spring washer	4	J1AP2-5001010	←	←	←	For Cord cover
8	349	Plate D	1	ECP5924AF	←	←	←	For Direct connection
9	401	Connection box	1	MR1DS9401	←	←	←	
10	411	Connection box cover	1	MR1DS9411	←	←	←	
11	421	Connection box packing	1	MR1DS9421	←	←	←	
12	422	Machine screw with spring washer	4	J1AP2-5001010	←	←	←	For Connection box cover
13	423	Spacer	4	M6SE010S9517	←	←	←	
14	424	Machine screw with spring washer	4	J1AP2-8002020	←	←	←	For Connection box assemble
15	1445	Plate complete set	1					*
16	5445	Plate assembly	1	MR2DS5445	←	←	←	
17	451	Machine screw with spring washer	3	J1AP2-4000808	←	←	←	For earth
18	452	Machine screw with spring washer	2	J1AW2-4001212	←	←	←	For Terminal
19	453	Machine screw with spring washer	2	J1AP2-4001616	←	←	←	For Electromagnetic contactor 871
20	457	Machine screw with spring washer	2	J1AP2-4001212	←	←	←	For Electromagnetic contactor 873
21	853	Terminal 16P	1	ECP1416AA	←	←	←	
22	871	Electromagnetic contactor	1					For traveling *
23	873	Electromagnetic contactor	1					For emergency stop *
24	454	Machine screw with spring washer	4	J1AP2-5001010	←	←	←	For plate assemble
25	1751	Relay cable 4C assembly	1					For Power supply *
26	1570	Holder assembly	1	ECP5924BA	ECP5924BB	←	←	
27	751	Relay cable 4C	1					*
28	752	Plug 4P	1	ECP2304AD	ECP2304AE	←	←	For Plug connection
29	341	Holder A	1	ECP5924AA	←	←	←	For Direct connection
30	351	Cable packing	1	ECP6914AA	←	←	←	For Direct connection
31	1761	Relay cable 6C assembly	1					For Operation *
32	1570	Holder assembly	1	ECP5924BB	←	←	←	
33	761	Relay cable 6C	1					*
34	762	Plug 8P	1	ECP2108AB	←	←	←	For Plug connection
35	341	Holder A	1	ECP5924AA	←	←	←	For Direct connection
36	351	Cable packing	1	ECP6914AA	←	←	←	For Direct connection
37	818	Cord cover packing	2	M7SE010S9527	←	←	←	
38	820	Machine screw with spring washer	4	J1AP2-5001010	←	←	←	For Socket 8P assembly or Plate D
39	1811	Socket 8P assembly	1					For Plug connection *
40	700	Name plate B	1	MR2SJC10S9A6 MR2SJC10L9A6	MR2SJC20S9A6 MR2SJC20L9A6	MR2SJC30S9A6 MR2SJC30L9A6	MR2SJC50S9A6 MR2SJC50L9A6	For standard speed For low speed

* The part codes vary depending on the power supply voltage.

Connection box related (Single speed type)

In Diagram	Part Number	Part Name	Quantity per unit	Product code				Summary
				MR2-010S/L	MR2-020S/L	MR2-030S/L	MR2-050S/L	
41	721	Name plate C	1	MR2SJC01S9A7 (125kg)	MR2SJC15S9A7 (1.5t)	MR2SJC25S9A7 (2.5t)	MR2SJC50S9A7 (5t)	For Name plate B
				MR2SJC03S9A7 (250kg)	MR2SJC20S9A7 (2t)	MR2SJC28S9A7 (2.8t)	X	
				MR2SJC05S9A7 (500kg)	X	MR2SJC30S9A7 (3t)	X	
				MR2SJC10S9A7 (1t)	X	X	X	
42	711	Warning seal E	1	E2DPX10S9866	←	←	←	Electric shock
43	814	Flat head machine screw	4	J1AL2-4001212	←	←	←	For Socket 8P

Connection box related (Dual speed inverter (VFD) type)

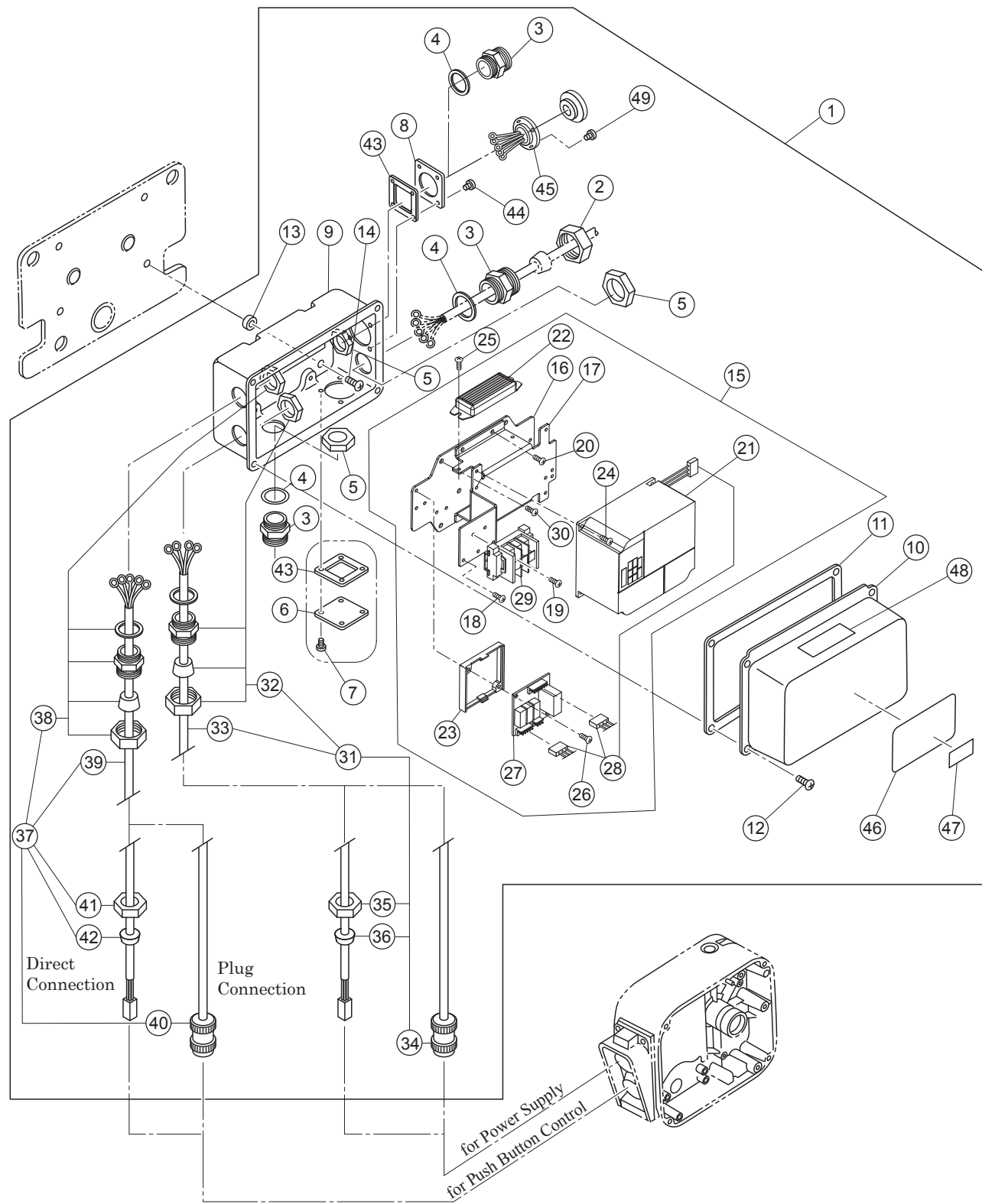

Connection box related (Dual speed inverter (VFD) type)

In Diagram	Part Number	Part Name	Quantity per unit	Product code				Summary
				MR2-010IS	MR2-020IS	MR2-030IS	MR2-050IS	
1	1401	Connection box complete set	1					*
2	341	Holder A	1	ECP5924AA	←	←	←	
3	342	Holder B	2/3	ECP5924AB	←	←	←	Direct connection provides 3 pieces
4	343	Packing	2/3	ECP5924AC	←	←	←	Direct connection provides 3 pieces
5	344	Holder nut	2/3	ECP5924AD	←	←	←	Direct connection provides 3 pieces
6	347	Cord cover	1	E6LE010S9630	←	←	←	
7	348	Machine screw with spring washer	4	J1AP2-5000808	←	←	←	For Cord cover
8	349	Plate D	1	ECP5924AF	←	←	←	For Direct connection
9	401	Connection box	1	MR1DS9401	←	←	←	
10	411	Connection box cover	1	MR1DS9411	←	←	←	
11	421	Connection box packing	1	MR1DS9421	←	←	←	
12	422	Machine screw with spring washer	4	J1AP2-5001010	←	←	←	For Connection box cover
13	423	Spacer	4	M6SE010S9517	←	←	←	
14	424	Machine screw with spring washer	4	J1AP2-8002020	←	←	←	For Connection box assemble
15	1445	Plate complete set	1					*
16	441	Plate	1	MR2DI9441	←	←	←	
17	443	Plate B	1	MR2DI9443	←	←	←	
18	451	Machine screw with spring washer	3	J1AP2-4000808	←	←	←	For earth
19	452	Machine screw with spring washer	2	J1AW2-4000808	←	←	←	For Terminal
20	467	Machine screw with spring washer	4	J1AP2-4000808	←	←	←	For plate B
21	1571	VFD assembly	1					*
22	573	Braking resistor	1					*
23	575	Board support	1	ECP99BKAB	←	←	←	
24	580	Machine screw with spring washer	2/4	J1AP2-4001010	←	←	←	For VFD, 2 pieces for 200V and 4 pieces for 400V
25	581	Machine screw with spring washer	2	J1AW2-4000808	←	←	←	For Braking resistor
26	582	Machine screw with spring washer	2	J1AP2-4001616	←	←	←	For Interface board and Board support
27	716	Interface board	1	ECP91KB11	←	←	←	
28	863	VFD lead wire	1set					*
29	853	Terminal 3P	1	ECP1403AA	←	←	←	
30	454	Machine screw with spring washer	4	J1AP2-5001010	←	←	←	For Plate complete set
31	1751	Relay cable 4C assembly	1					For Power supply *
32	1570	Holder assembly	1	ECP5924BA	ECP5924BB	←	←	
33	751	Relay cable 4C	1					*
34	752	Plug 4P	1	ECP2304AD	ECP2304AE	←	←	For Plug connection
35	341	Holder A	1	ECP5924AA	←	←	←	For Direct connection
36	351	Cable packing	1	ECP6914AA	←	←	←	For Direct connection
37	1761	Relay cable 6C assembly	1					For Operation *
38	1570	Holder assembly	1	ECP5924BB	←	←	←	
39	761	Relay cable 6C	1					*
40	762	Plug 8P	1	ECP2108AB	←	←	←	For Plug connection
41	341	Holder A	1	ECP5924AA	←	←	←	For Direct connection
42	351	Cable packing	1	ECP6914AA	←	←	←	For Direct connection
43	818	Cord cover packing	2	M7SE010S9527	←	←	←	
44	820	Machine screw with spring washer	4	J1AP2-5001010	←	←	←	For Socket 8P assembly or Plate D
45	1811	Socket 8P assembly	1					For Plug connection *
46	700	Name plate B	1	MR2SJC10I9A6	MR2SJC20I9A6	MR2SJC30I9A6	MR2SJC50I9A6	For standard speed

* The part codes vary depending on the power supply voltage.

Connection box related (Dual speed inverter (VFD) type)

In Diagram	Part Number	Part Name	Quantity per unit	Product code				Summary
				MR2-010IS	MR2-020IS	MR2-030IS	MR2-050IS	
47	721	Name plate C	1	MR2SJC01S9A7 (125kg)	MR2SJC15S9A7 (1.5t)	MR2SJC25S9A7 (2.5t)	MR2SJC50S9A7 (5t)	For Name plate B
				MR2SJC03S9A7 (250kg)	MR2SJC20S9A7 (2t)	MR2SJC28S9A7 (2.8t)	X	
				MR2SJC05S9A7 (500kg)	X	MR2SJC30S9A7 (3t)	X	
				MR2SJC10S9A7 (1t)	X	X	X	
48	711	Warning seal E	1	E2DPX10S9866	←	←	←	Electric shock
49	814	Flat head machine screw	4	J1AL2-4001212	←	←	←	For Socket 8P

Connection box related (Dual speed type, 500V class)

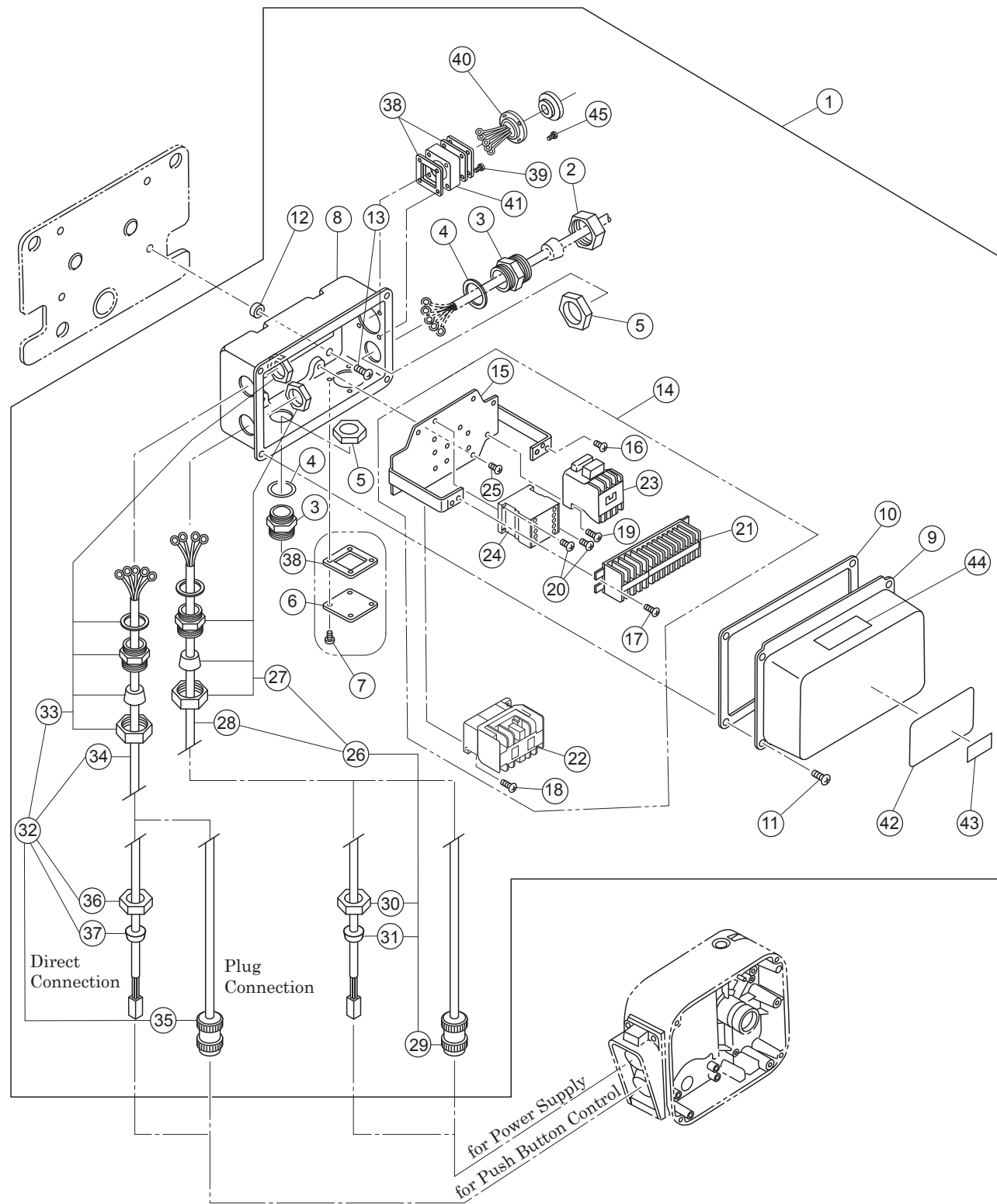

Connection box related (Dual speed type, 500V class)

In Diagram	Part Number	Part Name	Quantity per unit	Product code				Summary
				MR2-010SD	MR2-020SD	MR2-030SD	MR2-050SD	
1	1401	Connection box complete set	1	MR2DFA10J1A4	MR2DFA20J1A4	←	←	
2	341	Holder A	1	ECP5924AA	←	←	←	
3	342	Holder B	2	ECP5924AB	←	←	←	
4	343	Packing	2	ECP5924AC	←	←	←	
5	344	Holder nut	2	ECP5924AD	←	←	←	
6	347	Cord cover	1	E6LE010S9630	←	←	←	
7	348	Machine screw with spring washer	4	J1AP2-5001010	←	←	←	For Cord cover
8	401	Connection box	1	MR1DS9401	←	←	←	
9	411	Connection box cover	1	MR1DS9411	←	←	←	
10	421	Connection box packing	1	MR1DS9421	←	←	←	
11	422	Machine screw with spring washer	4	J1AP2-5001010	←	←	←	For Connection box cover
12	423	Spacer	4	M6SE010S9517	←	←	←	
13	424	Machine screw with spring washer	4	J1AP2-8002020	←	←	←	For Connection box assemble
14	1445	Plate complete set	1					*
15	5445	Plate assembly	1	MR2DS5445	←	←	←	
16	451	Machine screw with spring washer	3	J1AP2-4000808	←	←	←	For earth
17	452	Machine screw with spring washer	2	J1AW2-4001212	←	←	←	For Terminal
18	453	Machine screw with spring washer	2	J1AP2-4001616	←	←	←	For Electromagnetic contactor 871
19	456	Machine screw with spring washer	2	J1AW2-4001414	←	←	←	For Electromagnetic contactor 872
20	457	Machine screw with spring washer	2	J1AP2-4001212	←	←	←	For Electromagnetic contactor 873
21	853	Terminal 16P	1	ECP1416AA	←	←	←	
22	871	Electromagnetic contactor	1	MGC22302A	←	←	←	For traveling
23	872	Electromagnetic contactor	1	MGC11222B	←	←	←	For 500V class dual speed
24	873	Electromagnetic contactor	1	MGC12302A	←	←	←	For emergency stop
25	454	Machine screw with spring washer	4	J1AP2-5001010	←	←	←	For plate assemble
26	1751	Relay cable 4C assembly	1	MR2DS1751	MR2ES1751	←	←	For Power supply
27	1570	Holder assembly	1	ECP5924BA	ECP5924BB	←	←	
28	751	Relay cable 4C	1					*
29	752	Plug 4P	1	ECP2304AD	ECP2304AE	←	←	For Plug connection
30	341	Holder A	1	ECP5924AA	←	←	←	For Direct connection
31	351	Cable packing	1	ECP6914AA	←	←	←	For Direct connection
32	1761	Relay cable 6C assembly	1	MR2DS1761	MR2ES1761	←	←	For Operation
33	1570	Holder assembly	1	ECP5924BB	←	←	←	
34	761	Relay cable 6C	1					*
35	762	Plug 8P	1	ECP2108AB	←	←	←	For Plug connection
36	341	Holder A	1	ECP5924AA	←	←	←	For Direct connection
37	351	Cable packing	1	ECP6914AA	←	←	←	For Direct connection
38	818	Cord cover packing	3	M7SE010S9527	←	←	←	
39	820	Machine screw with spring washer	4	J1AP2-5003030	←	←	←	For Socket 8P assembly
40	1811	Socket 8P assembly	1	MR2DB1811	←	←	←	
41	361	Socket holder	1	ECP5924AK	←	←	←	
42	701	Name plate B	1	MR2SJC10S9A8	←	←	←	

* The part codes vary depending on the power supply voltage.

Connection box related (Dual speed type, 500V class)

In Diagram	Part Number	Part Name	Quantity per unit	Product code				Summary
				MR2-010SD	MR2-020SD	MR2-030SD	MR2-050SD	
43	721	Name plate C	1	MR2SJC01S9A7 (125kg)	MR2SJC15S9A7 (1.5t)	MR2SJC25S9A7 (2.5t)	MR2SJC50S9A7 (5t)	For Name plate B
				MR2SJC03S9A7 (250kg)	MR2SJC20S9A7 (2t)	MR2SJC28S9A7 (2.8t)	X	
				MR2SJC05S9A7 (500kg)	X	MR2SJC30S9A7 (3t)	X	
				MR2SJC10S9A7 (1t)	X	X	X	
44	711	Warning seal E	1	E2DPX10S9866	←	←	←	Electric shock
45	814	Flat head machine screw	4	J1AL2-4001212	←	←	←	For Socket 8P

Push button related

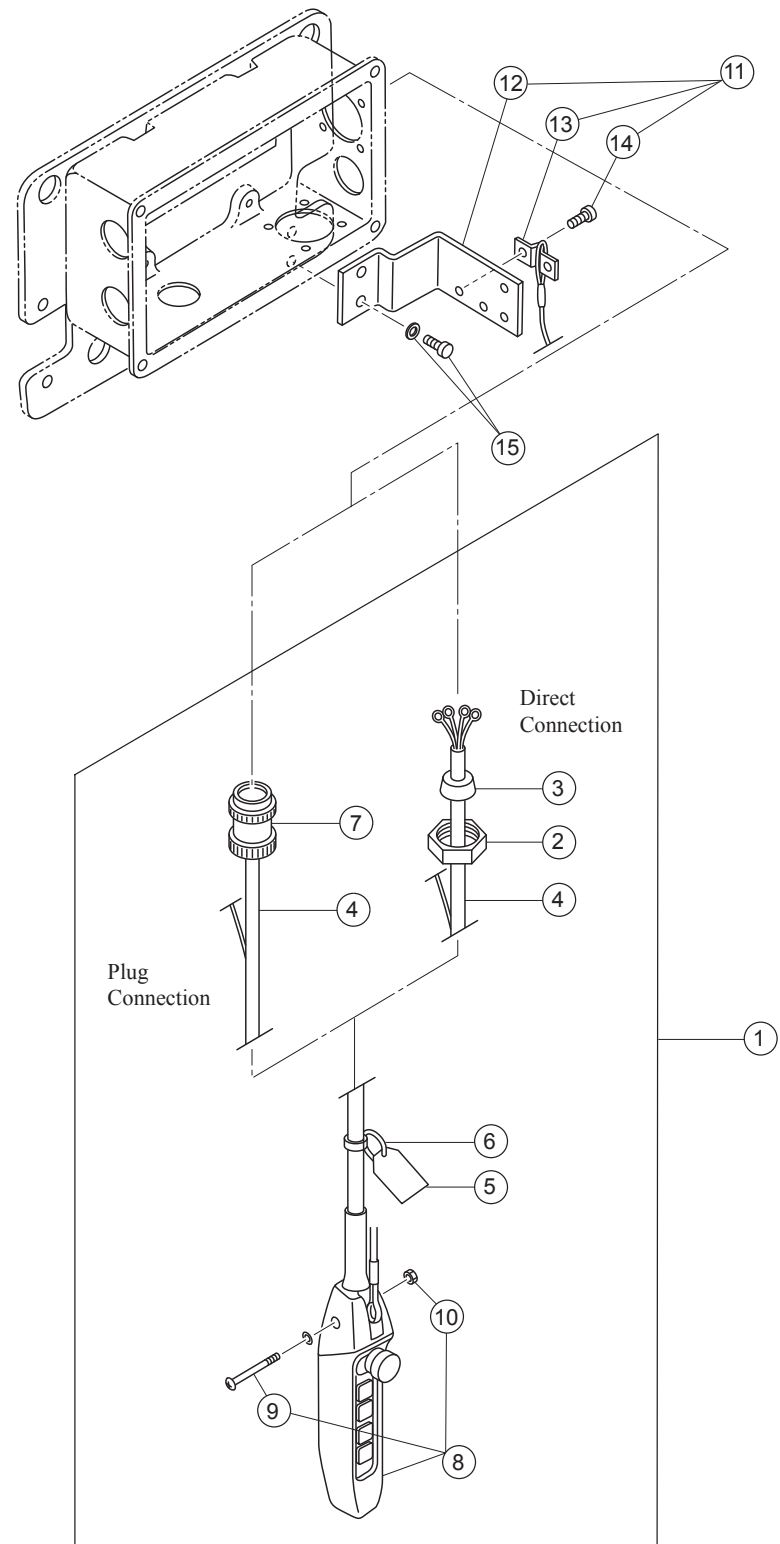

Push button related

In Diagram	Part Number	Part Name	Quantity per unit	Product code				Summary
				ER-Single speed MR-Single speed	ER-Dual speed MR-Single speed	ER-Single speed MR-Dual speed	ER-Dual speed MR-Dual speed	
1	1781	Push button cord 6C/7C/8C assembly	1					*
2	341	Holder A	1	ECP5924AA	←	←	←	For direct connection
3	351	Cable packing	1	ECP6916AA	←	←	←	For direct connection
4	781	Push button cord 7C/8C/9C	1					*
5	783	Warning tag PB	1	SWD9013AB	←	←	←	
6	784	Tag holder	1	E7SE003S9787	←	←	←	
7	792	Plug 8P	1					For plug connection *
8	1801	5 push button switch assembly	1					*
9	788	Machine screw with spring washer	1	J1AP2-4002608	←	←	←	
10	789	Nut	1	J1NA004-10040	←	←	←	

In Diagram	Part Number	Part Name	Quantity per unit	Product code				Summary
				MR2-010S/L/IS/SD	MR2-020S/L/IS/SD	MR2-030S/L/IS/SD	MR2-050S/L/IS/SD	
11	1481	Bar holder assembly	1	MR1DS1481	←	←	←	
12	481	Bar holder	1	MR1DS9481	←	←	←	
13	816	Cord chain stopper	1	E6LE010S9614	←	←	←	
14	817	Machine screw with spring washer	2	J1AP2-6001212	←	←	←	For cord chain stopper
15	482	Socket bolt with spring washer	2	J1BG1-1002828	←	←	←	For bar holder

* The part codes vary depending on the power supply voltage.

Power supply cable related/Accessory related/Trolley cable related

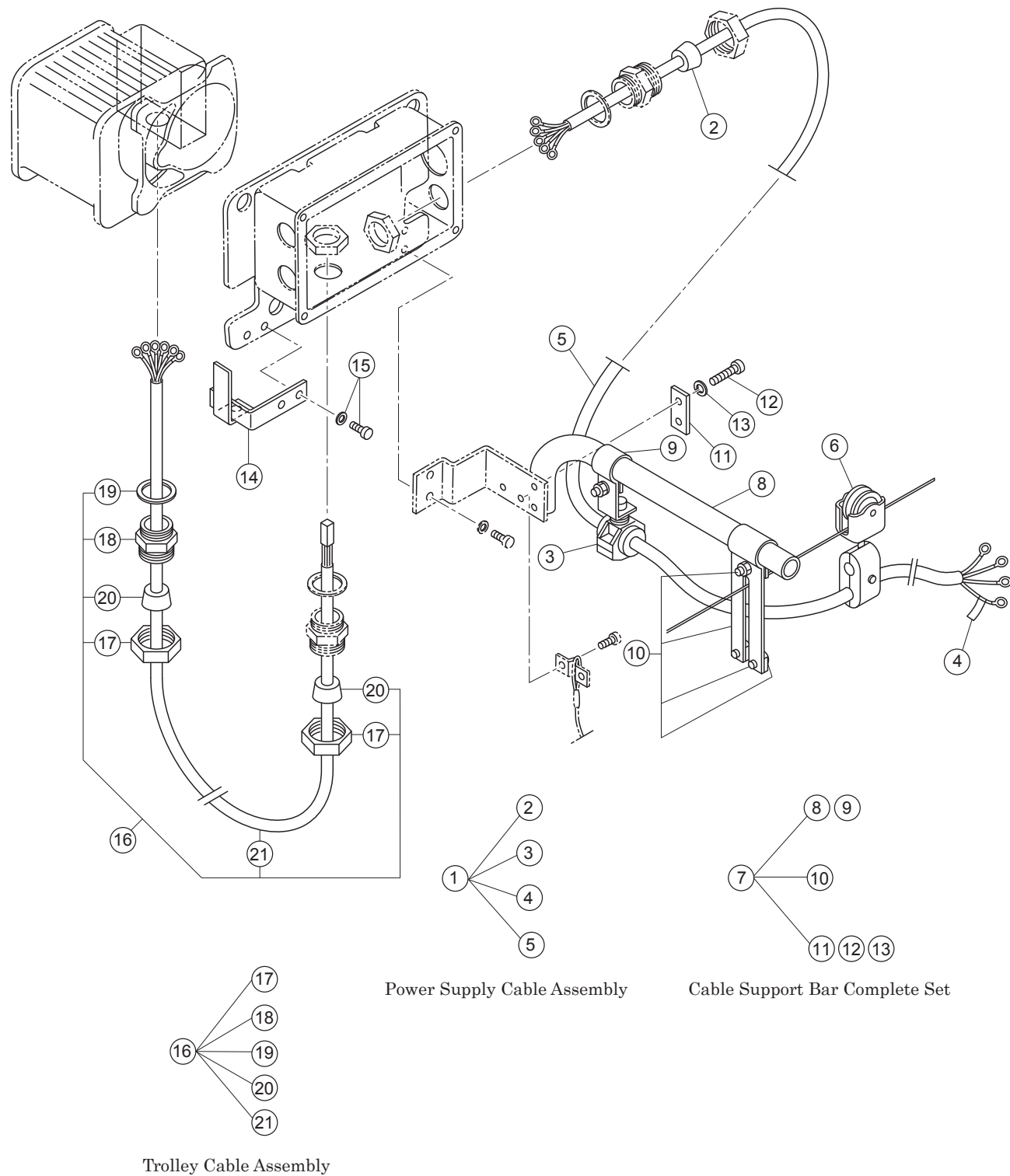

Power supply cable related/Accessory related/Trolley cable related

Power supply cable related

In Diagram	Part Number	Part Name	Quantity per unit	Product code				Summary	
				MR2-010S/L MR2-010IS/SD	MR2-020S/L MR2-020IS		MR2-030S/L MR2-030IS/SD		MR2-050S/L MR2-050IS/SD
					ER2-015S/IS/SD ER2-020L/IL/LD	Other			
1	1771	Power supply cable 4C assembly	1					4c for non-thermal *	
2	351	Cable packing	1	ECP6914AA	←	ECP6916AA	←	←	
3	1724	Cable support 14 assembly	1	E4YS005-2822	←	M3ES010-1724	←	←	
4	741	Name plate G	1	E6LE010S9806	←	←	←	←	
5	771	Power supply cable 4C	1					4c for non-thermal *	
6	1641	Cable hanger 14 assembly	n	E6AX003S1527	←	←	←	←	

Accessory related

In Diagram	Part Number	Part Name	Quantity per unit	Product code				Summary
				MR2-010S/L/IS/SD	MR2-020S/L/IS/SD	MR2-030S/L/IS/SD	MR2-050S/L/IS/SD	
7	1491	Cable support bar complete set	1	MR1DS1491	←	←	←	For power supply cable
8	491	Cable support bar	1	MR1DS9491	←	←	←	
9	492	Cable support arm	1	MR1DS9492	←	←	←	
10	1493	Wire guide assembly	1	MR1DS1493	←	←	←	
11	501	Support bar holder (plate)	1	MR1DS9501	←	←	←	
12	505	Bolt	2	J1BA2-0803030	←	←	←	For support bar holder (plate)
13	506	Spring lock washer	2	J1WS012-20080	←	←	←	For support bar holder (plate)
14	511	Cable hanger pusher	1	MR1DS9511	x	x	x	For T-type hanger (MR1t, Beam 75mm)
	512	Cable hanger pusher	1	MR1DS9512	←	←	x	For T-type hanger (MR1t-3t, Beam 100-150mm)
	511	Cable hanger pusher	1	x	x	x	MR1GS9511	For T-type hanger (MR5t, Beam125-175mm)
15	516	Socket bolt with spring washer	2	J1BG1-1002828	←	←	←	For cable hanger pusher

Trolley cable related

In Diagram	Part Number	Part Name	Quantity per unit	Product code		Summary
				MR2-010S/L/IS/SD MR2-020S/L/IS/SD MR2-030S/L/IS/SD	MR2-050S/L/IS/SD	
16	1791	Trolley cable 4C/6C/8C assembly	1		*	
17	341	Holder A	2	ECP5924AA	←	
18	342	Holder B	1	ECP5924AB	←	
19	343	Packing	1	ECP5924AC	←	
20	351	Cable packing	2			*
21	791	Trolley cable 4C/6C	1			*

* The part codes vary depending on the power supply voltage.

< Memo >

< Memo >

KITO

Global Website: kito.com