OWNER'S (OPERATOR'S) MANUAL AND SAFETY INSTRUCTIONS FOR ED SERIES ELECTRIC CHAIN HOIST (MODEL ED III)

BEFORE USING THIS PRODUCT :

ALWAYS SAVE THIS BOOK FOR FUTURE REFERENCE

ALWAYS READ OWNER'S (OPERATOR'S) MANUAL AND SAFETY INSTRUCTIONS

- ⚠ WARNING** : **IMPROPER electric chain hoist use could result in death or serious injury. To avoid these hazards:**
- : **NEVER hoist loads over or near people.**
 - : **NEVER work under or near hoisted loads.**
 - : **ALWAYS operate, inspect, and maintain this hoist in accordance with applicable safety codes and regulations.**

These safety instructions contain important information to help you use the chain hoist in a safe manner. Please refer to this Owner's (Operator's) Manual for additional safety information.

KITO

CONTENTS

DEFINITIONS	1
1. BEFORE USE	1
1-1. Safety Summary	1
1-2. Safety Instructions	2
2. MAIN SPECIFICATIONS	6
3. PREPARATION AND CHECKING BEFORE USE	9
3-1. Packed Contents	9
3-2. Preparation and Checking Before Use	9
3-3. Installing Trolley	13
4. OPERATION	15
4-1. Single-speed Type	15
4-2. Dual-speed Type	15
4-3. Dual-speed Cylinder Type	16
4-4. Electric Chain Hoist with Trolley	17
5. INSPECTION	18
5-1. Inspection Classification	18
5-2. Frequent Inspection	18
5-3. Periodic Inspection	19
5-4. Occasionally Used Hoists	21
5-5. Inspection Record	21
5-6. Inspection Methods and Judgment Criteria	22
6. MAINTENANCE	26
6-1. Gear Lubrication	26
6-2. Load Chain Lubrication	26
6-3. Mechanical Brake with Friction Clutch	27
7. CONNECTION DIAGRAM	27
7-1. Single-speed Type	28
7-2. Dual-speed Type and Dual-speed Cylinder Type	30
8. TROUBLE-SHOOTING AND SOLUTIONS	32
9. WARRANTY	34
10. PARTS LIST	35

DEFINITIONS

⚠ DANGER : indicates an imminently hazardous situation which, if not avoided, **WILL** result in death or serious injury.

⚠ WARNING : indicates a potentially hazardous situation which, if not avoided, **COULD** result in death or serious injury.

⚠ CAUTION : indicates a potentially hazardous situation and/or unsafe practice which, if not avoided, **MAY** result in **MINOR** or **MODERATE** injury and/or property damage.

1. BEFORE USE

1-1. Safety Summary

Danger exists when heavy loads are transported, particularly when the equipment is not being used properly or is poorly maintained. Because accidents and serious injury could result, special safety precautions apply to the operation, maintenance and inspection of the Electric Chain Hoist.

Following these simple rules can help to avoid hoisting accidents;

⚠ WARNING : **IMPROPER** electric chain hoist use could result in death or serious injury. To avoid these hazards:

NEVER use a hoist for lifting, supporting or transporting people.

NEVER lift or transport loads over or near people.

NEVER work near or under hoisted loads.

NEVER lift more than rated load.

ALWAYS let people around you know when a lift is about to begin.

ALWAYS make sure that the supporting structures and load-attaching device are strong enough to hold the weight of the load and hoist.

ALWAYS read Owner's (Operator's) Manual and safety instructions.

Remember, proper rigging and lifting techniques are the responsibility of the operator. Be sure you read and understand the instructions contained in this manual before using your hoist. Check all applicable safety codes, regulations and other applicable laws for further information about the safe use of your hoist.

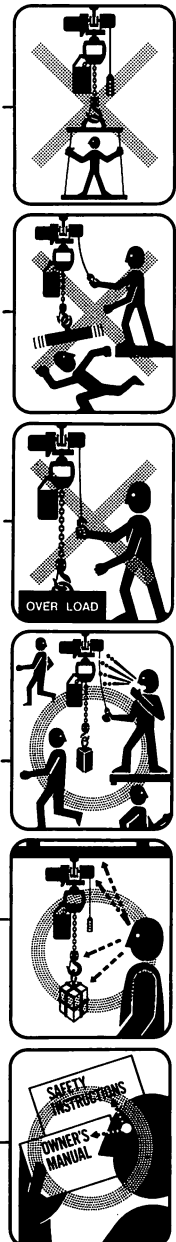

More detailed safety information is contained in the following pages. For additional information, please contact Kito Corporation or your authorized Kito dealer.

1-2. Safety Instructions

Serious injury could result if the following safety instructions are not followed.

⚠ WARNING : **IMPROPER electric chain hoist use could result in death or serious injury.**

To avoid these hazards:

“ALWAYSs”

- ALWAYS** allow only qualified (trained in safety and operation) people to operate the hoist.
- ALWAYS** operate a hoist only if you are physically fit.
- ALWAYS** check the hoist before daily use according to the Recommended Daily Inspection (Refer to Sec. 5).
- ALWAYS** let the authorized personnel inspect the hoist periodically (Refer to Sec. 5).
- ALWAYS** make sure that the chain length is long enough for the intended job.
- ALWAYS** check that the hook latches are in proper working order before use (Refer to Sec. 5-6).
- ALWAYS** replace all missing or broken hook latches.
- ALWAYS** be sure that the hoist's rated capacity, which is found on the hoist's label, is well in excess of the weight of the load.
- ALWAYS** make sure that you and others are clear of the load before lifting begins.
- ALWAYS** be sure that the load is properly seated in the saddle of the hook.
- ALWAYS** keep the load from hitting the chain.
- ALWAYS** use two hoists which each has rated capacities equal to or more than the load to be lifted whenever you must use two hoists to lift a load. This will provide adequate protection in the event that a sudden load shift or failure of one hoist occurs.

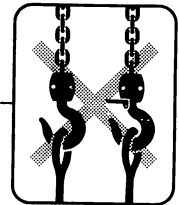

ALWAYS check the brake before use (Refer to Sec. 5-6)

ALWAYS check for loose or missing parts before use.

ALWAYS lubricate the hoist regularly (Refer to Sec. 6).

ALWAYS use the specified gear oil.-----



ALWAYS pay attention to the load at all times when operating the hoist.

ALWAYS ease the slack out of the chain and sling when starting a lift to prevent a sudden loading.

ALWAYS use a hoist only between the allowable ambient temperature from -20°C (-4°F) and to $+40^{\circ}\text{C}$ ($+104^{\circ}\text{F}$).

ALWAYS secure a hoist and loads properly after use.

ALWAYS consult the manufacturer or your dealer if you plan to use a hoist in a dusty, moist or greasy environment.

ALWAYS consult the manufacturer or your dealer if you plan to use a hoist in an excessively corrosive environment. (Salt-water, sea air and/or acid or other corrosive compounds)

ALWAYS make sure that all persons stay clear of the suspended load.

ALWAYS maintain firm footing when operating hoist.

ALWAYS avoid unnecessary inching of hoist control.

ALWAYS make the hoist motor completely stop before reversing.

ALWAYS ground the electric chain hoist before using.

ALWAYS use a hoist within the rating of the electrical motor.

ALWAYS be familiar with hoist operating controls, procedures and warnings.

ALWAYS make sure the brake functions properly before use.

ALWAYS use the hoist manufacturer's recommended parts when repairing a hoist.

ALWAYS use the end of the trolley side frames to contact the rail-stops.

ALWAYS shut power off from its source and lock out before servicing is performed.-----



⚠ WARNING : **IMPROPER electric chain hoist use could result in death or serious injury. To avoid these hazards:**

“NEVERs”

- NEVER** use the hoist to transport people.
- NEVER** lift a load over people.
- NEVER** work near or under hoisted loads.
- NEVER** operate a hoist if damaged or malfunctioning.
- NEVER** use a hoist which has been taken out of service until the hoist has been properly repaired or replaced.
- NEVER** use a hoist if the hook latch is missing or broken.
- NEVER** operate unless the load is centered under the hoist.
- NEVER** splice a hoist chain.
- NEVER** use the hoist chain as a sling.
- NEVER** force a chain or hook into place by hammering.
- NEVER** jerk a load to prevent a sudden loading.
- NEVER** use a twisted, kinked, damaged or stretched load chain.
- NEVER** swing a suspended load.
- NEVER** support a load on the tip of the hook.
- NEVER** suspend a load for an extended period of time.
- NEVER** leave a suspended load unattended.
- NEVER** run the load chain over a sharp edge.
- NEVER** weld or cut a load suspended by a hoist.
- NEVER** use the hoist chain as a welding electrode.
- NEVER** wind so far that the hook touches the hoist body.
- NEVER** unwind so far that no unloaded chain is left.
- NEVER** operate a hoist if chain jumping, excessive noise, jamming, overloading or binding occurs.
- NEVER** allow your attention to be diverted from operating the hoist.

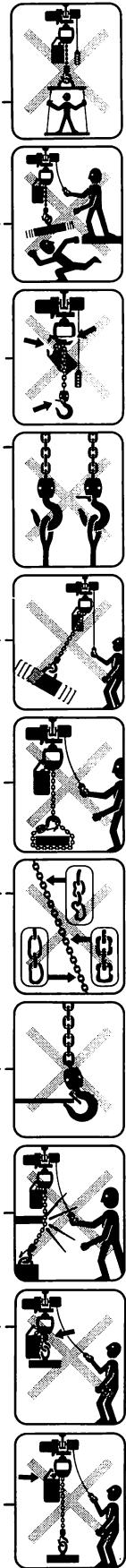

- NEVER** dropping or releasing a load could result in death or serious injury. To avoid this hazard, do not operate the bottom hook release mechanism (hook cam) when the hoist with cylinder-controlled or optional detachable hook is under load.
- NEVER** use a hoist in flammable atmosphere where explosion is possible.
- NEVER** use the limit switch or friction clutch on a regular basis. These devices are for emergency use only.
- NEVER** adjust or repair a hoist unless qualified people to perform hoist maintenance.
- NEVER** use the railstops to exert impact force on the hoist or the trolley.
- NEVER** use a hoist without a chain stopper at the end of no-loaded side chain.
- NEVER** attempt to lengthen the load chain or repair damaged load chain.
- NEVER** adjust or repair the mechanical brake with friction clutch unless qualified people to perform hoist maintenance.
- NEVER** pull the push button cord.
- NEVER** use a hoist beyond 10% higher than the actual power source voltage. (Refer to Sec. 3-2, (5))
- NEVER** throw a hoist.
- NEVER** use a hoist without a name plate or warning labels or with illegible name plate or labels.
- NEVER** remove or obscure the warning tags.
- NEVER** use modified or deformed hooks.
- NEVER** use a hoist near fire or where hot objects may touch it.
- NEVER** touch live electrical parts.
- NEVER** use the electric chain hoist without grounding it.
- NEVER** ground the electric chain hoist to a gas pipe as this can create the possibility of explosion.
- NEVER** handle the arm-fitting during the hoist operation.
- NEVER** throw or drop the hoist when carrying it.

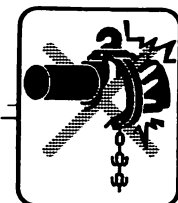
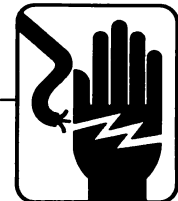
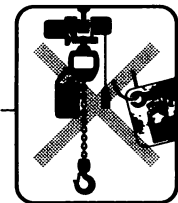
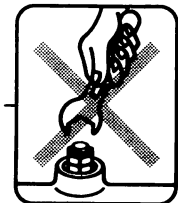

WARNING TAGS are installed on a cord.

2. MAIN SPECIFICATIONS

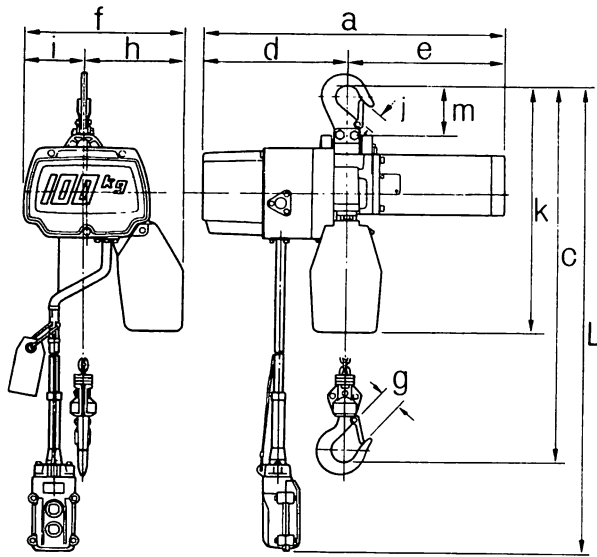

Single-speed type
Dual-speed type

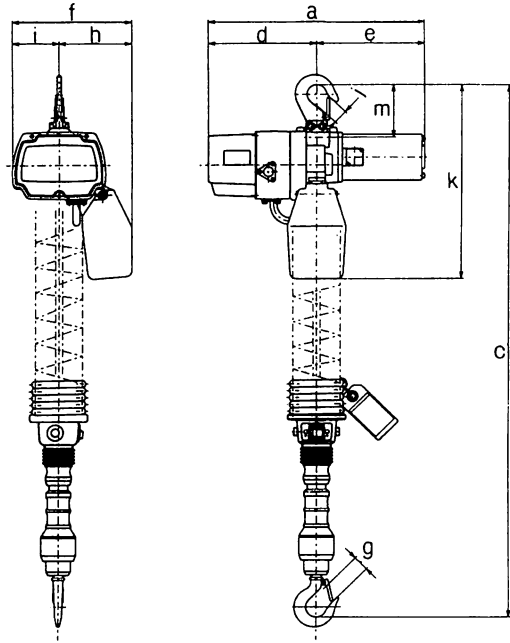

Dual-speed cylinder type

Specifications and dimensions of AC120V type

Rated power source		AC120V single phase, 50/60Hz																				
Type		Single-speed type						Dual-speed type						Dual-speed cylinder type								
Model		ED06S	ED10S	ED18S	ED16S	ED24S	ED48S	ED06ST	ED10ST	ED18ST	ED16ST	ED24ST	ED48ST	EDC06SD	EDC10SD	EDC18SD	EDC16SD	EDC24SD				
Rated load (kg)		60	100	180	160	240	480	60	100	180	160	240	480	60	100	180	160	240				
Motor output (W)		300			600			300			600			300			600					
Time rating (min)		15	10	20	15	15	10	20	15	15	10	20	15	15	10	20	15	10				
Intermittent duty	Duty rating (%ED)	30	20	30	30	30	20	30	20	30	20	30	20	30	20	30	20	30				
	Max. starting frequency (times/h)	180	120	180	180	180	120	180	120	180	120	180	120	180	120	180	120	180				
Rated current (A)		5	6	10	10	5	6	10	5	6	10	10	5	6	10	10	5	6				
Lifting speed (m/min)		21	13	8	20	13.5	6.7	High speed:21 Low speed: 4	High speed:13 Low speed: 3	High speed: 8 Low speed: 3	High speed:20 Low speed: 4	High speed:13.5 Low speed: 3	High speed:6.7 Low speed: 2	High speed:21 Low speed: 4	High speed:13 Low speed: 3	High speed: 8 Low speed: 3	High speed:20 Low speed: 4	High speed:13.5 Low speed: 3				
Standard lift (m)		3						3						1.8								
Push-button cord length : L (m)		2.5						2.5						-								
Load chain diameter (mm)		4						4						4								
Net weight (kg)		11.5 (12.0)※1		15.5 (16.0)※1		21 (21.5)※1		12.0 (12.5)※1			16.0 (16.5)※1			21 (21.5)※1			14.5 (15.0)※1			18.5 (19.0)※1		
Min. headroom: C (mm)		315		330		520		315			330			520			945			960		
Dimensions (mm)	a	371		428		428		371			428			428			371			428		
	d	187		205		205		187			205			205			187			205		
	e	184		223		223		184			223			223			184			223		
	f	205		219		229		205			219			229			205			219		
	h	125		135		155		125			135			155			125			135		
	i	80		84		74		80			84			74			80			84		
	g	25				24		25						24		25						
	j	25				24		25						24		25						
	k	340		362		454		340			362			454			340			362		
m	92				149		92						149		92							

※1 : these net weight at control voltage of 30 V

Specifications and dimensions of AC240V type

Rated power source		AC240V single phase, 50/60Hz																
Type		Single-speed type						Dual-speed type						Dual-speed cylinder type				
Model		ED06S	ED10S	ED18S	ED16S	ED24S	ED48S	ED06ST	ED10ST	ED18ST	ED16ST	ED24ST	ED48ST	EDC06SD	EDC10SD	EDC18SD	EDC16SD	EDC24SD
Rated load (kg)		60	100	180	160	240	480	60	100	180	160	240	480	60	100	180	160	240
Motor output (W)		300			600			300			600			300			600	
Time rating (min)		20	15	20	20	20	15	20	20	20	15	20	20	20	15	20		
Intermittent duty	Duty rating (%ED)	30	20	30			30	20	30			30	20	30				
	Max. starting frequency (times/h)	180	120	180			180	120	180			180	120	180				
Rated current (A)		3			5			3			5			3			5	
Lifting speed (m/min)		21	13	8	20	13.5	6.7	High speed:21 Low speed: 4	High speed:13 Low speed: 3	High speed: 8 Low speed: 3	High speed:20 Low speed: 4	High speed:13.5 Low speed: 3	High speed:6.7 Low speed: 2	High speed:21 Low speed: 4	High speed:13 Low speed: 3	High speed: 8 Low speed: 3	High speed:20 Low speed: 4	High speed:13.5 Low speed: 3
Standard lift (m)		3						3						1.8				
Push-button cord length : L (m)		2.5						2.5						-				
Load chain diameter (mm)		4						4						4				
Net weight (kg)		11.5 (12.0)※1		15.5 (16.0)※1		21 (21.5)※1		12.0 (12.5)※1		16.0 (16.5)※1		21 (21.5)※1		14.5 (15.0)※1		18.5 (19.0)※1		
Min. headroom: C (mm)		315		330		520		315		330		520		945		960		
Dimensions (mm)	a	364		428		428		364		428		428		364		428		
	d	187		205		205		187		205		205		187		205		
	e	177		223		223		177		223		223		177		223		
	f	205		219		229		205		219		229		205		219		
	h	125		135		155		125		135		155		125		135		
	i	80		84		74		80		84		74		80		84		
	g	25			24			25			24			25				
	j	25			24			25			24			25				
	k	340		362		454		340		362		454		340		362		
m	92			149			92			149			92					

※1 : these net weight at control voltage of 30 V

Notes: (1) The power supply cable is 2 mm² × 5 m (3 conductors).

(2) Hoisting speed is the average value of wind-up and -down speed under rated voltage, rated frequency, and rated load conditions. Speed may differ by voltage and load conditions.

(3) Non-standard lengths of lift (load chain) and push-button cord of the single- and dual-speed types are also available upon request.

⚠ CAUTION : NEVER use the hoist with power source voltage exceeds rated voltage by more than 10%. (Refer to Sec. 3-2)

Additionally, these 3 types of electric chain hoists are available for normal voltage operation and low-voltage (30V) operation. Further, these chain hoists can be used under the different voltages as shown in next page.

The lifting speed varies according to the actual power source voltage as shown in next page.

Relationship between power source voltage and lifting speed

Rated voltage (V)	Actual power source voltage / Operation voltage (V)	Lifting speed (m/min)					
		300w			600w		
		60kg	100kg	180kg	160kg	240kg	480kg
120	110/110	19.3	11.9	7.3	18.3	12.4	6.1
	110/27.5						
	115/115	20.1	12.5	7.7	19.2	12.9	6.4
	115/29						
	120/120	21	13	8	20	13.5	6.7
	120/30						
240	220/220	19.3	11.9	7.3	18.3	12.4	6.1
	220/27.5						
	230/230	20.1	12.5	7.7	19.2	12.9	6.4
	230/29						
	240/240	21	13	8	20	13.5	6.7
	240/30						

3. PREPARATION AND CHECKING BEFORE USE

3-1. Packed Contents

Before using, make sure the following contents are packed:

Hoist unit (containing oil)

Chain container (including bolt, nut, and split pin for attaching to hoist unit)

Push-button cord (the dual-speed cylinder type is equipped with a curled cord and fastening belt.)

Load chain

Power supply cable

3-2. Preparation and Checking Before Use

The appearance and profile are as shown in the next;

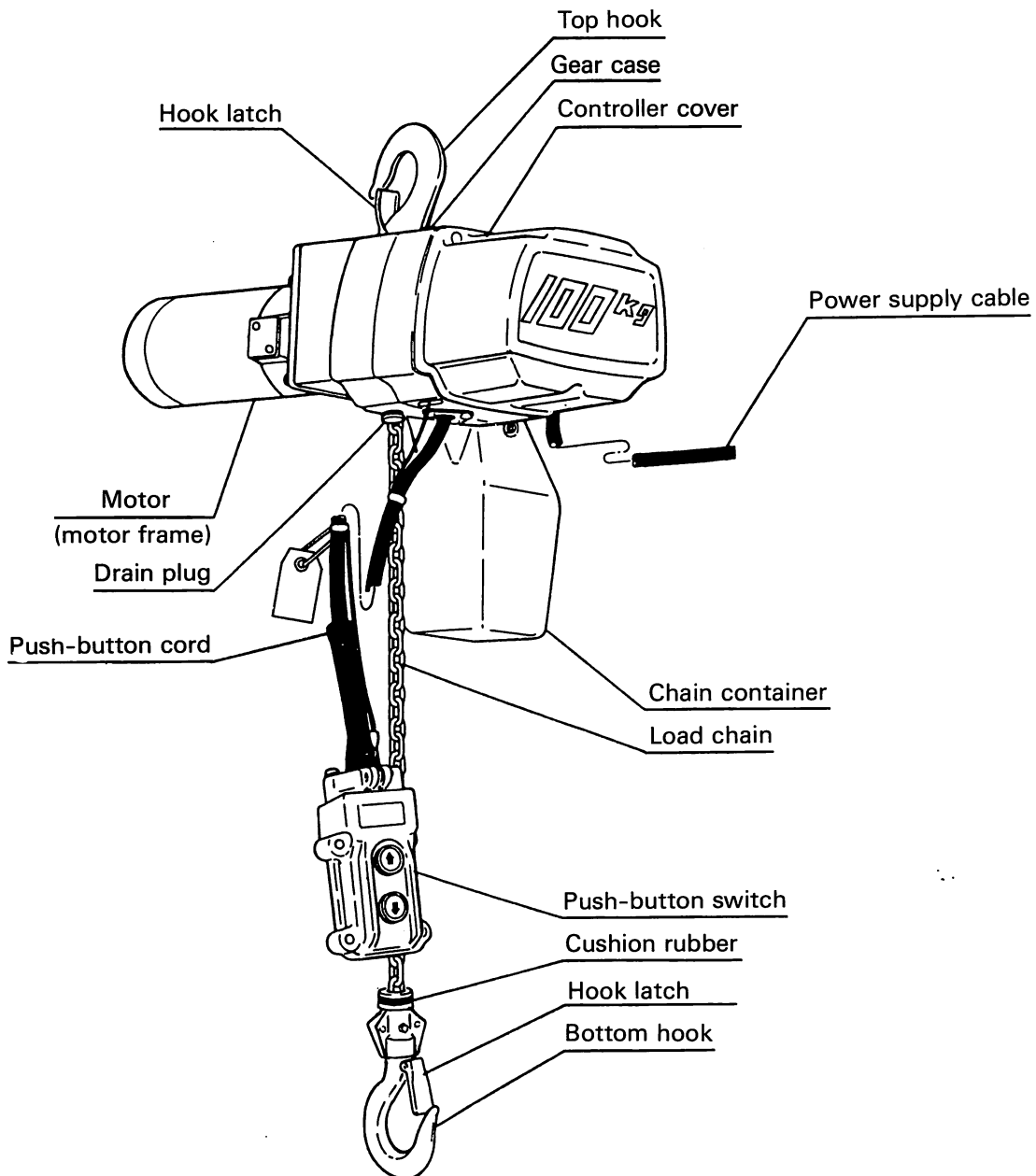

Single-speed type

BEFORE USING, PREPARE AND CHECK THE FOLLOWING FIVE ITEMS.

(1) GEAR OIL SUPPLY

Gear oil is pre-supplied in the gear box.

To change gear oil: Remove oil plug and drain plug from gear box. Drain contaminated oil completely, fasten drain plug, supply the specified gear oil sufficiently from the oil plug hole, then firmly fasten the oil plug.

⚠ WARNING : Use of the hoist without sufficient oil can cause immediate and severe damage to the hoist's gear and clutch mechanisms, which can result in hoist malfunctioning and possible death or serious injury. To avoid these hazards, never use the chain hoist without sufficient oil. Refer to the following table.

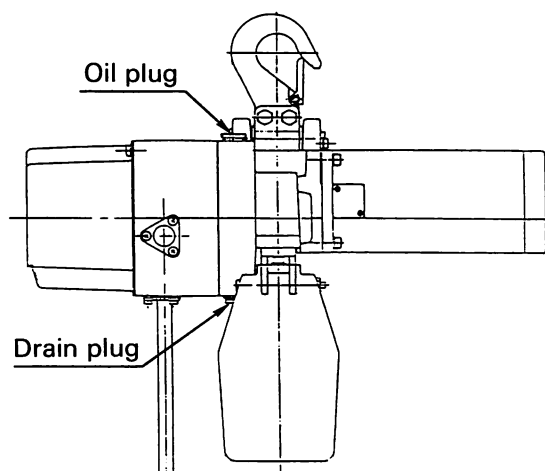

Gear oil quantity

Rated load (kg)	Optimal oil quantity (ℓ)
60	0.27
100	
180	
160	0.35
240	
480	

⚠ WARNING : Use of oils other than the specified Kito's exclusive gear oil might not allow full exertion of the built-in friction clutch, which can cause load to drop. To avoid these hazards: ALWAYS use the specified Kito's exclusive gear oil.



⚠ WARNING : To avoid oil leak, make sure to firmly fasten drain plug.

(2) CHAIN CONTAINER FITTING

The chain container stores the load chain of the no-load side. In connecting it to the hoist body, fasten it completely and pay attention to the following points:

⚠ WARNING : Firmly fasten bolt and nut as shown in the following figure appearing on the next page.

⚠ WARNING : ALWAYS be sure that the load chain of the no-load side is properly stored in the chain container and folded correctly from the end.

⚠ WARNING : NEVER store chain in the chain container which exceed the specified length of the chain container.

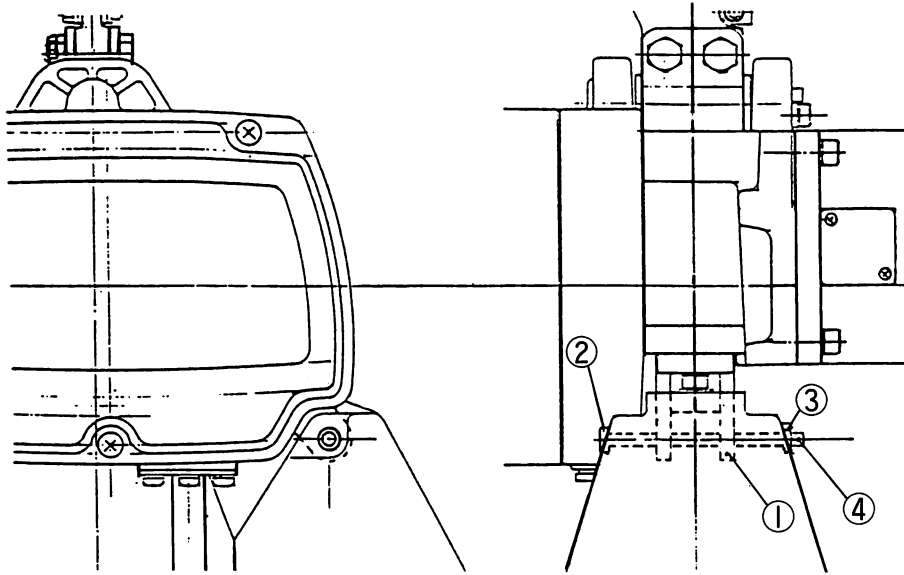

Fitting Procedure:

- * Attach the chain container to the chain guide ① with socket bolt ② and U-nut ③.
- * Attach the split pin ④ to prevent the U-nut ③ from dropping. Bend pin ends 90° or more

(3) ATTACHING PUSH-BUTTON AND CURLED CORDS

a. Single- and dual-speed types

While the push-button cord is being connected to the hoist body, the strain relief wire may not be connected yet. After the push button cord connecting, be sure to attach the end of the strain relief wire to the hoist body.

⚠ WARNING : Short-circuit and electric shock may result if the push-button cord is pulled when the strain relief wire is not connected to the hoist body. **ALWAYS** make sure that the strain relief wire is properly attached to the hoist body as depicted and described in the next.

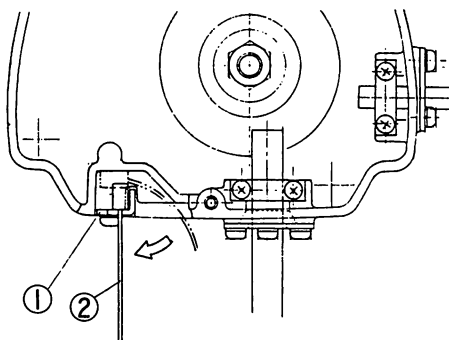

Fitting procedure:

* As illustrated, hook the strain relief wire ② to the cable support L ① of the hoist body.

b. Dual-speed cylinder type

While the curled cord is being connected to the hoist body, it may not be fixed to the chain container yet. As illustrated, attach it to the chain container so that the clamp of the fastening belt faces the way it does in the figure and so that the load chain comes to the center of the curled cord at that time.

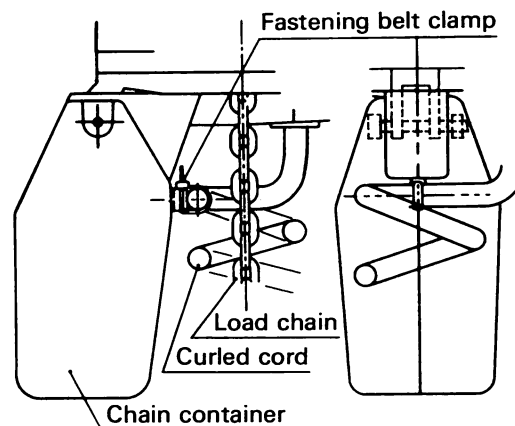

⚠ WARNING : To avoid damage on the curled cord, fix the curled cord to the chain container with the fixing band.

⚠ WARNING : To avoid wearing between load chain and chain guide, straighten up load chain before fitting the curled cord to the chain container.

⚠ WARNING : To avoid damaging the curled cord, attach the chain container so that the fastening belt clamp faces up.

(4) LUBRICATING THE LOAD CHAIN

⚠ WARNING

Chain lubrication is a critical factor in the service life of a load chain. Apply enough machine or gear oil regularly.

Lubrication Procedures

- Vertically suspend the chain under no load conditions.
- Remove dust or water drops from the chain.
- Apply lubricant around the sections where the chain links come into contact with each other and the load sheave or idle sheave as shown in the following figures.

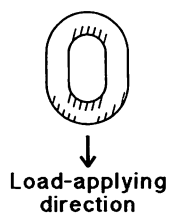

- After the chain lubrication is done, lift and lower without any load to spread the lubricant thoroughly.

Please consult with KITO Corporation if any of lubricants are not allowed at your site.

(5) POWER SUPPLY CABLE ATTACHMENT

A 2 mm² × 5 m (3-conductors) power supply cable is normally supplied.

When power source is far away and an extension supply cable is required, use a cable of sufficient diameter as illustrated in the following table.

Extension cable diameter (nominal cross-section area of conductor)	Max. length of extension cable (m)
2.0 mm ²	30
1.25 mm ²	15

⚠ CAUTION : The extension cable should be a 3-conductors cable with the specified cross-section area of the conductor.

[Connection to power supply source]

⚠ WARNING : ALWAYS ground the electric chain hoist before using.

⚠ DANGER : NEVER ground the electric chain hoist to a gas pipe as this can create the possibility of explosion.

⚠ DANGER : In addition to grounding, ALWAYS connect to a power supply source equipped with an earth leakage breaker.

⚠ CAUTION : Actual power source voltage should not exceed max. allowable voltage in the following table.

Actual power source voltage (V)	Max. allowable voltage (V)
110	121
115	126
120	132
220	242
230	253
240	264

3-3. Installing Trolley

(1) MINI TROLLEY

* Attachment of adjusting spacers

Remove the top hook of the electric chain hoist and connect the adjusting spacers to the trolley, utilizing the top yoke.

A total of 32 adjusting spacers are prepared. Number of spacers differs with rail width. As illustrated, attach adjusting spacers so that dimension A = dimension B (rail width) + 3 mm (approx.).

(Reference)

Rail width		Inside trolley frame	Outside trolley frame
50	H-steel	Right/left, 8 pcs. each	Right/left, 8 pcs. each
68	H-steel	Right/left, 11 pcs. each	Right/left, 5 pcs. each
	I-steel		
98	H-steel	Right/left, 16 pcs. each	Right/left, 0 pcs. each
100	I-steel		

⚠ WARNING : Incorrect number of adjusting spacers may cause the trolley not to move or to drop. To avoid these hazards:
ALWAYS make sure to use all 32 pieces and confirm that $A - B \doteq 3 \text{ mm}$.

*** Fitting of socket bolt**

Set the trolley so that the wheel axis is right angle to the load line. Attach the socket bolt, nut and U nut (double nut system), adjusting the clearance of 2mm or less between the split pin hole and U nut with 2 Adjusting Spacers and 2 Adjusting Spacer-Bs, and then tighten them and secure the split pin to the bolt.

⚠ WARNING : To avoid the trolley from dropping, firmly fasten the socket bolt, nut and U-nut. Insert split pin and bend its ends 90° or more.

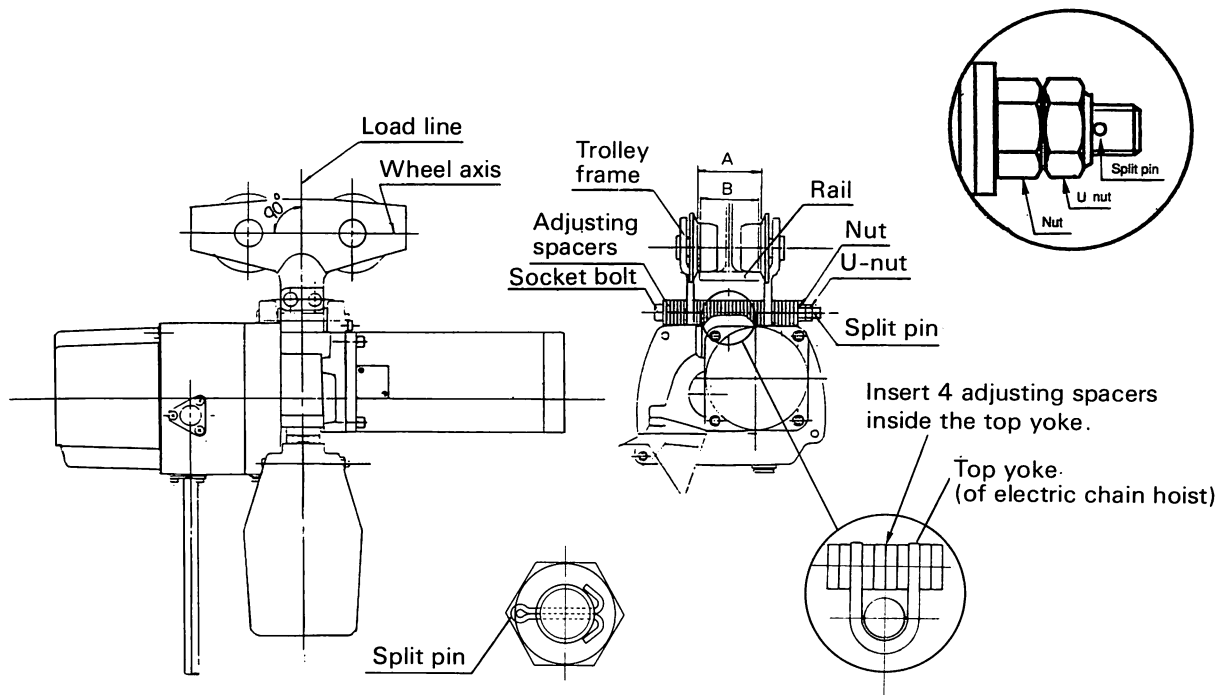

(2) INSTALLING TROLLEY TO RAIL

⚠ WARNING : For all trolley suspended electric chain hoists, rail stops must be installed at each end of the rail. Failure to install rail stops will allow the hoist and trolley to fall off the end of the rail and thus cause an accident that could result in injury and/or property damage. The stops must be positioned so as to not exert impact force on the electric chain hoist frame or trolley wheels. They must contact the ends of the trolley side frames.

⚠ WARNING : Rail stops should be attached with buffers to alleviate trolley impact force.

(3) TS series trolley (480kg only)

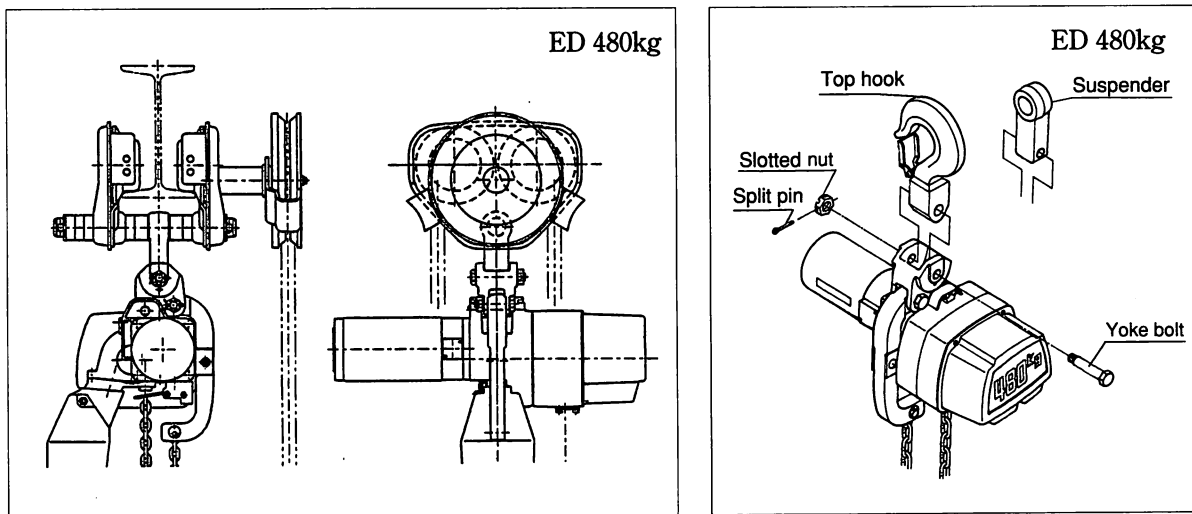



※ For more details of connection with TS series trolley, refer to the manual of TS series trolley.

4. OPERATION

As soon as pre-usage preparation and checks have been completed, the hoist will be ready for operation.

⚠ WARNING : In shifting operation between lifting up and lowering down under the loaded condition, ensure to avoid the immediate reverse operation before the hoist motor completely stops. If not avoided, it could result in the hoist's damage. Ensure to avoid the excessive inching operation. (Inching operation: very frequent lifting or lowering operations in a very short time for positioning the hook with very small repeated hook movements.) If not avoided, it could result in the hoist's damage.

4-1. Single-speed Type

The push-button switch is single-step push-in type.
Push  to lift and  to lower.

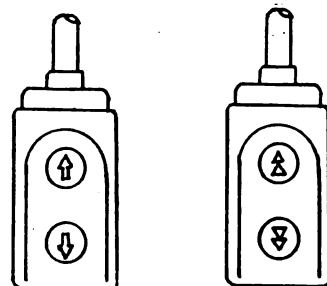

Single-speed type Dual-speed type

4-2. Dual-speed Type

The push-button switch is dual-step push-in type. The first step is for low-speed operation and the second step for high-speed. Push ⊕ to lift and ⊖ to lower.

[Low-speed adjustment procedure]

The push-button can be adjusted by setting the low-speed side for the operating voltage of each country. However, if the low speed does not work or is too fast or slow (owing to voltage and frequency fluctuation), adjust the switch in the following way:

⚠ DANGER : NEVER touch live portions of cables, terminals, and terminal screws during adjustment so as not to incur electric shock.

ALWAYS make sure to turn power off before servicing.

- * Open the back lid of the push-button switch. (as depicted in the next illustration)
- * Turn the volume clockwise to increase speed or counterclockwise to lower it.
- * Close the back lid of the push-button switch.

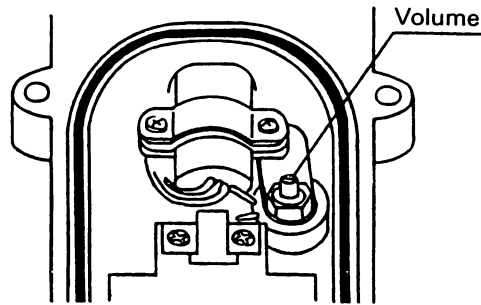

4-3. Dual-speed Cylinder Type

(1) This is a handling switch type hoist. The switch is directly attached to the bottom hook. As illustrated, the switch is cylinder shaped. Load is lifted when the switch is flipped up and lowered when flipped down.

- * The operation box has an alternate lighting switch.
- * High or low lifting speed is selected by the alternate switch.
- * "H" on the left side for high speed, "L" on the right side for low speed.

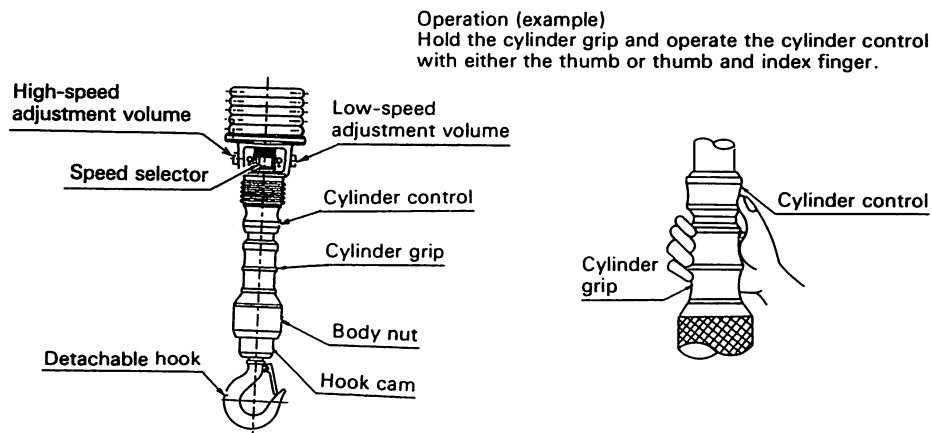

[Speed adjustment procedure]

If the hoist does not operate or have the proper speed, adjust the speed volume as follows:

- * For increasing the lifting speed, turn the volume clockwise.
- * For decreasing the lifting speed, turn the volume counterclockwise.

(2) The bottom hook is detachable. Detachment and setting are described next.

* To detach bottom hook:

Holding the body nut, turn the hook cam to the left (counterclockwise).

* To set the bottom hook:

The bottom hook can be set by simply pushing it in from underneath.

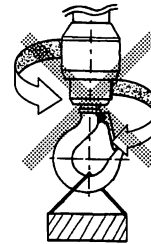

⚠ WARNING : ALWAYS make sure the hook cam is completely locked.

⚠ WARNING : NEVER dropping or releasing a load could result in death or serious injury. To avoid this hazard, do not operate the bottom hook release mechanism (hook cam) when the hoist with cylinder-controlled or optional detachable hook is under load.

4-4. Electric Chain Hoist with Trolley

To operate the electric chain hoist with trolley, move it horizontally by either pushing the lifted load or the load chain.

⚠ WARNING : NEVER pull the curled cord, push-button switch or push-button cord. Pulling the curled cord, push-button switch or push-button cord may disconnect cord wires. Disconnected wire(s) may cause a short-circuit in the hoist body or any surrounding conductor, giving the operator electric shock.

⚠ WARNING : ALWAYS move the horizontally by grasping the cylinder grip or pushing the load.

⚠ WARNING : ALWAYS pay your attention on your back when you attempts to push a lifted load or the load chain.

5. INSPECTION

5-1. Inspection Classification

- (a) INITIAL inspection – prior to initial use, all new, altered, or modified hoists shall be inspected by a designated person to ensure compliance with the applicable provisions of this Manual.
- (b) Inspection procedure for hoists in regular service is divided into two general classifications based upon the intervals at which inspection should be performed. The intervals in turn are dependent upon the nature of the critical components of the hoist and the degree of their exposure to wear, deterioration, or malfunction. The two general classifications are herein designated, as FREQUENT and PERIODIC, with respective intervals between inspections as defined below.
 - (1) FREQUENT inspection – visual examinations by the operator or other designated personnel.
 - (a) normal service – monthly
 - (b) heavy service – weekly to monthly
 - (c) severe service – daily to weekly
 - (d) special or infrequent service – as recommended by a qualified person before and after each occurrence
 - (2) PERIODIC inspection – visual inspection by a designated person.
 - (a) normal service – yearly
 - (b) heavy service – semiannually
 - (c) severe service – quarterly
 - (d) special or infrequent service – as recommended by a qualified person before the first such occurrence and as directed by the qualified person for any subsequent occurrences.

5-2. Frequent Inspection (see table)

Items such as those listed below shall be inspected for defects and damage at intervals as defined in Sec. 5-1 (b) (1). This includes observations during operation for any defects or damage that might appear between PERIODIC inspections. A designated person shall determine whether any defects or damage constitute a hazard or will require more detailed inspection.

- a. Trace slipping via braking.
- b. Control functions for optimal operation.
- c. Damage, cracks, and bends in hooks or noticeable opening.
- d. Setting the hook latch ; hook latch operation.
- e. Optimal luburication, signs of wear, link damage, or adhesion of foreign matter to the load chain.
- f. Load sheave engagement with load chain ; load chain twisting.

- g. Idle sheave engagement with load chain ; load chain twisting.
- h. Proper limit switch actuation and motor stopping when the hook rises at upper limit under no load.
- i. No deformed, peeled and cracked cushion rubber.
- j. No damaged chain spring (option), and minimum free length, 75mm (130mm), of the chain spring.

Note: Initial free length of the spring 85mm(150mm).

* () : 60 ~ 240kg

5-3. Periodic Inspection (see table)

Complete inspections of the hoist shall be performed at intervals as defined in Sec. 5-1 (b) (2). These inspections may be performed with the hoist in its normal location and do not require that the entire hoist be dismantled. Covers and other items normally supplied to allow inspection of components should be opened or removed for these inspections. Any deficiencies such as those listed below shall be examined by a designated person to determine whether they constitute a hazard, or whether complete disassembly is necessary. These inspections shall include the requirements of Sec. 5-2.

- a. Inspection to all items included in FREQUENT inspection.
- b. Fastening of screws, bolts, and nuts.
- c. Wear, corrosion, cracks, distortion, etc., of the gear, bearings and chain pins.
- d. Damage to the hook or fittings that attach the hook to the chain.
- e. Damage to or excessive wear of the load sheave chain pocket:
If the chain pocket is too wide or deep, the chain may be lifted up over the pocket or may get caught between the chain guide and load sheave.
Also check the chain guide for wear around the opening through which the chain enters the hoist.
* Extremely worn or damaged parts should be changed.
- f. For the friction clutch, see Sec. 6-3.
- g. Pitching of contactor contact point deterioration:
Operate the push buttons and check if it sticks at any point.
- h. Imperfect insulation of cables, cords, and the control station.

TABLE INSPECTION FOR ELECTRIC CHAIN HOISTS

Item	Normal Service		Heavy Service		Strict Service	
	Visual Monthly	Record Yearly	Visual Weekly	Record Semiannually	Visual Daily	Record Quarterly
FREQUENT inspection (see 5-2)						
All functional operating mechanisms for maladjustment and unusual sounds	*	—	*	—	*	—
Brake slippage (see 5-2.a.)	*	—	*	—	*	—
Optimal control functions (see 5-2.b.)	*	—	*	—	*	—
Hook damage, crack, bend and opening (see 5-2.c.)	*	—	*	—	*	—
Hook latch operation (see 5-2.d.)	*	—	*	—	*	—
Optimal load chain lubrication (see 5-2.e.)	*	—	*	—	*	—
Load chain in accordance with 5-2.e.	*	—	*	—	*	—
Load chain reeving for compliance with hoist manufacturer's recommendations	*	—	*	—	*	—
Load sheave engagement with load chain:load chain twisting.	*	—	*	—	*	—
Idle sheave engagement with load chain:load chain twisting.	*	—	*	—	*	—
Proper limit switch actuation and motor stopping when the hook rises at upper limit under no load.	*	—	*	—	*	—
No deformed, peeled and cracked cushion rubber.	*	—	*	—	*	—
No damaged chain spring(option), and minimum free length 75mm(130mm), of the chain spring. Note : Initial free length of the spring 85mm(150mm). * (): 60 ~ 240kg	*	—	*	—	*	—
PERIODIC inspection (see 5-3)						
Requirements of frequent inspection	—	*	—	*	—	*
Evidence of loose bolts, nuts or rivets (see 5-3.b.)	—	*	—	*	—	*
Evidence of worn, corroded, cracked, or distorted parts such as load blocks, suspension housing, chain, attachments, clevises, yokes, suspension bolts, shafts, gears, bearings and pins. (see 5-3.c.)	—	*	—	*	—	*
Imperfect insulation of cables, cord and control station (see 5-3.h.)	—	*	—	*	—	*
Evidence of damage or excessive wear of sheave (see 5-3.e.)	—	*	—	*	—	*
Evidence of excessive wear on friction clutch (see 5-3.f. 6-3)	—	*	—	*	—	*

TABLE INSPECTION FOR ELECTRIC CHAIN HOISTS

Item	<u>Normal Service</u>		<u>Heavy Service</u>		<u>Severe Service</u>	
	Visual Monthly	Record Yearly	Visual Weekly	Record Semiannually	Visual Daily	Record Quarterly
Electrical apparatus for signs of pitting or any deterioration of visible controller contacts (see 5-3.g.)	—	*	—	*	—	*
Evidence of damage of supporting structure or trolley, if used	—	*	—	*	—	*
Warning label	—	*	—	*	—	*
End connections of load chain	—	*	—	*	—	*

5-4. Occasionally Used Hoists



- (a) A hoist which has been idle for a period of 1 month or more, but less than 1 year, shall be given an inspection conforming with the requirements of Sec. 5-2 before it is placed in service.
- (b) A hoist which has been idle for a period of 1 year shall be given an inspection conforming with the requirements of Sec. 5-3 before it is placed in service.



5-5. Inspection Record

- (a) We recommend that dated inspection reports and records be maintained at time intervals specified in Sec. 5-1 (b) (2). We suggest strongly that records are stored where they be available to authorized persons.
- (b) We suggest strongly that a long-range chain inspection program be established and include records of examination of chains removed from service so a relationship could be established between visual observation and actual condition of the chain.

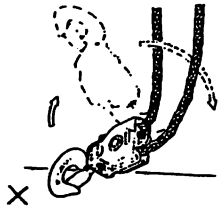
5-6. Inspection Methods and Judgment Criteria

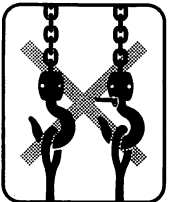
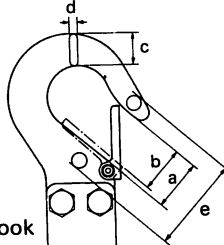
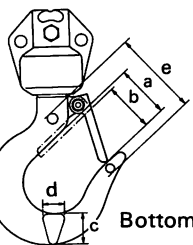
Item	Inspection Methods	Discard limit/criteria	Measures
1. HOIST BODY			
(1) Casing damage	Check visually.	<ul style="list-style-type: none"> • No cracks on hoist body. 	Replace.
(2) Abnormal sounds during operation	Lift and lower a light load.	<ul style="list-style-type: none"> • No vibration or irregular noise from the motor or from inside the hoist body. 	Overhaul.
(3) Gear oil quantity; contamination	Check visually.	<ul style="list-style-type: none"> • Change gear oil regularly, matching usage frequency. 	Replace.
(4) Controller cover damage	Check visually.	<ul style="list-style-type: none"> • No deformation or cracks. 	Replace.
(5) Name plate damage	Check visually.	<ul style="list-style-type: none"> • Capacity should be legible. 	Replace.
(6) Cable and cord joint damage	Check visually.	<ul style="list-style-type: none"> • No damage or loose screws. 	Replace/repair.
(7) Brake function	Check brake slipping on lifting or lowering with no load.	<ul style="list-style-type: none"> • Braking distance : approx. 5 chain links. 	Ask service shop to inspect and repair.
	Check brake slipping on lifting or lowering with rated load at high speed.	<ul style="list-style-type: none"> • Braking distance : approx. 5 chain links. 	Ask service shop to inspect and repair.
(8) Brush	Check visually.	<ul style="list-style-type: none"> • The discard limit of this brush is 8 mm (brush should not be worn past this limit). <div data-bbox="922 1155 1138 1325" style="text-align: center;"> <p>The diagram shows a cylindrical brush with a square cross-section. A dimension line with arrows at both ends is drawn across the width of the brush, labeled '8mm'.</p> </div>	Replace.
2. OPERATION SWITCH			
(1) Function	Operate switch with no load.	<ul style="list-style-type: none"> • The bottom hook shall lift and lower. • To change from low to high speed. (Dual-speed and dual-speed cylinder types) 	Check power source and make sure cord is connected. Replace if defective (electrical equipment included). Replace.
(2) Case cracking	Check visually.	<ul style="list-style-type: none"> • No cracks. 	Replace.
(3) Loose wiring joints	Check visually.	<ul style="list-style-type: none"> • No loosening or dropping of screws. 	Repair.

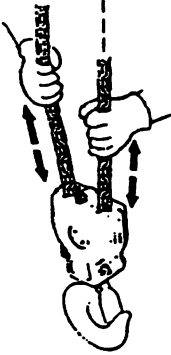
Item	Inspection Methods	Discard limit/criteria	Measures																																			
3. LOAD CHAIN (1) Appearance (2) Wear	Check visually. Measure with calipers.	<ul style="list-style-type: none"> • Load chain shall be oiled. • Dimension "P" or "d" shall be within the following values : 	Supply oil. Replace. Unit (mm)																																			
	<table border="1"> <thead> <tr> <th rowspan="2">Chain diameter (d)</th> <th rowspan="2">Number of measured chain links</th> <th colspan="2">Sum of pitches (P) of measured chain links</th> <th rowspan="2">Wear limit of d</th> </tr> <tr> <th>Normal</th> <th>Discard</th> </tr> </thead> <tbody> <tr> <td>4</td> <td>5</td> <td>60.5</td> <td>61.7</td> <td>3.3</td> </tr> </tbody> </table>	Chain diameter (d)	Number of measured chain links	Sum of pitches (P) of measured chain links		Wear limit of d	Normal	Discard	4	5	60.5	61.7	3.3																									
Chain diameter (d)	Number of measured chain links			Sum of pitches (P) of measured chain links			Wear limit of d																															
		Normal	Discard																																			
4	5	60.5	61.7	3.3																																		
(3) Load chain Appearance	Check visually for greasing and twisting.	Load chain is well lubricated.	If chain is dry, apply the specified lubricant in the section '3-2(4)'.																																			
	 	Load chain is not twisted or capsized.	If chain is twisted, untwist it and restore it to normal chain condition.																																			
4. HOOKS (1) Deformation	Check visually. Measure dimension "e" between two embossed marks at time of purchase with calipers. Measure with calipers.	<ul style="list-style-type: none"> • No deformation from original shape (at time of purchase). • No deformation from original shape (at time of purchase). • Never use the hook if dimension (c) or (d) becomes less than 90% of normal. • Dimensions "c" and "d" are within their limits. 	Replace. Replace. Replace.																																			
		<table border="1"> <thead> <tr> <th rowspan="2"></th> <th>a mm Normal size</th> <th>b mm Normal size</th> <th colspan="2">c mm</th> <th colspan="2">d mm</th> </tr> <tr> <th>Normal size</th> <th>Normal size</th> <th>Normal size</th> <th>Discard limit</th> <th>Normal size</th> <th>Discard limit</th> </tr> </thead> <tbody> <tr> <td>Bottom hook</td> <td>31.0</td> <td>25.0</td> <td>17.0</td> <td>15.3</td> <td>12.1</td> <td>10.9</td> </tr> <tr> <td>Top hook</td> <td>26.5</td> <td>25.0</td> <td>17.0</td> <td>15.3</td> <td>7.0</td> <td>6.3</td> </tr> <tr> <td rowspan="2">480 kg</td> <td>Bottom hook</td> <td rowspan="2">28.0</td> <td rowspan="2">24.0</td> <td rowspan="2">23.5</td> <td rowspan="2">21.0</td> <td rowspan="2">17.5</td> <td rowspan="2">16.0</td> </tr> <tr> <td>Top hook</td> </tr> </tbody> </table>		a mm Normal size	b mm Normal size	c mm		d mm		Normal size	Normal size	Normal size	Discard limit	Normal size	Discard limit	Bottom hook	31.0	25.0	17.0	15.3	12.1	10.9	Top hook	26.5	25.0	17.0	15.3	7.0	6.3	480 kg	Bottom hook	28.0	24.0	23.5	21.0	17.5	16.0	Top hook
	a mm Normal size	b mm Normal size		c mm		d mm																																
	Normal size	Normal size	Normal size	Discard limit	Normal size	Discard limit																																
Bottom hook	31.0	25.0	17.0	15.3	12.1	10.9																																
Top hook	26.5	25.0	17.0	15.3	7.0	6.3																																
480 kg	Bottom hook	28.0	24.0	23.5	21.0	17.5	16.0																															
	Top hook																																					
			Top hook Bottom hook																																			

Item	Inspection Methods	Discard limit/criteria	Measures
(2) Flaws	Check visually	<ul style="list-style-type: none"> • No deep flaws. 	Replace.
(3) Bend at shank of bottom hook	Check visually	<ul style="list-style-type: none"> • Never use if bent. 	Replace
(4) Bottom hook movement	Turn hook.	<ul style="list-style-type: none"> • Hook should turn lightly. 	Replace
(5) Deformation of lower metal fitting	Check visually.	<ul style="list-style-type: none"> • Should be free from deformation. 	Replace.
(6) Chain container damage	Check visually.	<ul style="list-style-type: none"> • Screws and pins should not be loosened or damaged. 	Replace.
(7) Hook latch	Check visually.	<ul style="list-style-type: none"> • No invasion of foreign matter. 	Repair.
(8) Rotation of idle sheave	Turn idle sheave by lifting the load chain up and down, as illustrated.	<p>The idle sheave rotates smoothly.</p> 	Inspect and repair if rotation is not smooth.
5. CHAIN SPRING AND CUSHION RUBBER			
(1) Chain spring deformation (Option)	Check visually.	<p>NEVER use deformed chain spring as illustrated or un-springy one, and make sure that the size of free chain spring is the minimum of 75mm (130mm), the initial size of the spring is 85mm (150mm). * (): 60 ~ 240kg</p> 	Replace chain spring with a new one if deformed.
(2) Cushion rubber deformation	Check visually.	<p>NEVER use cushion rubber if it is deformed as illustrated.</p> 	Replace cushion rubber with a new one if deformed.
6. ELECTRIC CABLE			
(1) Damage of electric cable	Check visually.	<ul style="list-style-type: none"> • No damage. 	Replace.
(2) Loose of electric cable connection	Check visually.	<ul style="list-style-type: none"> • No loosening. 	Repair.
(3) Poor grounding	Check visually.	<ul style="list-style-type: none"> • Should be grounded. 	Ground.

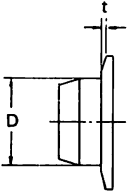
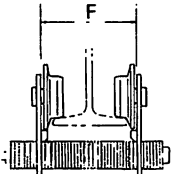
Item	Inspection Methods	Discard limit/criteria	Measures									
<p>7. MINI TROLLEY (60 ~ 240kg) In the case of 480kg, refer to the manual of TS series trolley.</p> <p>(1) Function</p> <p>(2) Falling of fasteners</p> <p>(3) Wheel wear</p>	<p>Move (trolley) under no-load condition.</p> <p>Check visually.</p> <p>Measure with calipers.</p> 	<ul style="list-style-type: none"> • Should run smoothly. • Not fall. • Contact face and flange wear should be within the following limits: <table border="1" data-bbox="759 710 1374 923"> <thead> <tr> <th colspan="2">Diameter of tread D (mm)</th> <th>Discard limit of flange</th> </tr> <tr> <th>Normal</th> <th>Discard limit</th> <th>t (mm)</th> </tr> </thead> <tbody> <tr> <td>40</td> <td>38</td> <td>1.5</td> </tr> </tbody> </table>	Diameter of tread D (mm)		Discard limit of flange	Normal	Discard limit	t (mm)	40	38	1.5	<p>Replace.</p> <p>Repair.</p> <p>Replace.</p>
Diameter of tread D (mm)		Discard limit of flange										
Normal	Discard limit	t (mm)										
40	38	1.5										
<p>(4) Frame deformation</p>	<p>Check visually.</p> <p>Measure with calipers.</p> 	<ul style="list-style-type: none"> • No deformation. • Frame top dimensions "F" Should not exceed dimensions before use by 5% or more. 	<p>Replace.</p> <p>Replace.</p>									

6. MAINTENANCE

- ⚠ WARNING** : IMPROPER electric chain hoist use could result in death or serious injury.
- To avoid these hazards:
- : NEVER perform maintenance on the hoist while it is supporting a load.
 - : Before performing maintenance, attach the tag:
[“DANGER” : DO NOT OPERATE EQUIPMENT BEING REPAIRED.]
 - : Only allow qualified service personnel to perform maintenance.
 - : ALWAYS lock-out power source before conducting maintenance.
 - : After performing any maintenance on the hoist, always test to its rated capacity before returning to service.

6-1. Gear Lubrication

Change gear oil at least once a year..

- ⚠ WARNING** : To change oil, ALWAYS remove both the oil plug and drain plug to drain determined oil completely before supplying the specified gear oil.
- : Use of oils other than the specified Kito's exclusive gear oil might not allow full exertion of the friction clutch, which can cause load to drop.
- To avoid these hazards:
- Always use the specified Kito's exclusive gear oil.

6-2. Load Chain Lubrication

Refer to '3-2 (4) LUBRICATING THE LOAD CHAIN

- ⚠ WARNING** : IMPROPER electric chain hoist use could result in death or serious injury.
- To avoid these hazard:
- ALWAYS** lubricate load chain weekly, or more frequently, depending on severity of service.
 - ALWAYS** lubricate more frequently than normal in corrosive environment. (Saltwater, sea air and/or acid or other corrosive compounds)
 - ALWAYS** clean chain with an acid free solvent only to remove rust or abrasive dust build-up. After cleaning, lubricate the chain.
 - ALWAYS** lubricate each link of the chain and apply new lubricant over existing layer.

6-3. Mechanical Brake with Friction Clutch

The mechanical brake with friction clutch has both slip clutch and brake functions.

⚠ WARNING : **IMPROPER** electric chain hoist use could result in death or serious injury.

To avoid these hazards:

- : **NEVER** disassemble and adjust the mechanical brake with friction clutch.
- : **ALWAYS** contact your local KITO dealer in case of malfunction of mechanical brake with friction clutch.

NOTICE : When starting to lift, you may hear a slight sharp noise from the hoist. This noise does not imply an abnormality of the hoist.

7. CONNECTION DIAGRAM

The electric instruments of the controller (contactor and converter) are installed on a panel and contained in the hoist body.

To check the connection, open the controller cover of the hoist body. Make sure that lead wires are connected correctly and firmly, referring to the following connection diagram.

⚠ DANGER : To avoid possible electric shock, **ALWAYS** make sure to turn off the power source before checking the connection.

7-1. Single-speed Type

(1) Normal voltage control type (120V)

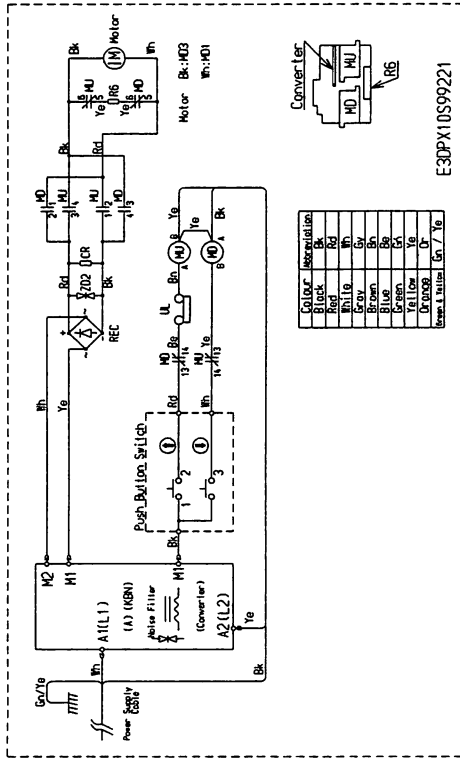

Motor output 300W
(Rated load 60kg, 100kg, 180kg)

(2) Normal voltage control type (240V)

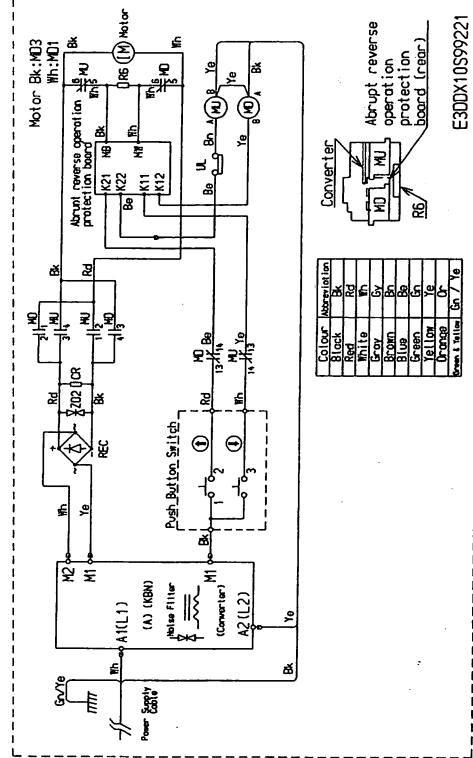

Motor output 300W
(Rated load 60kg, 100kg, 180kg)

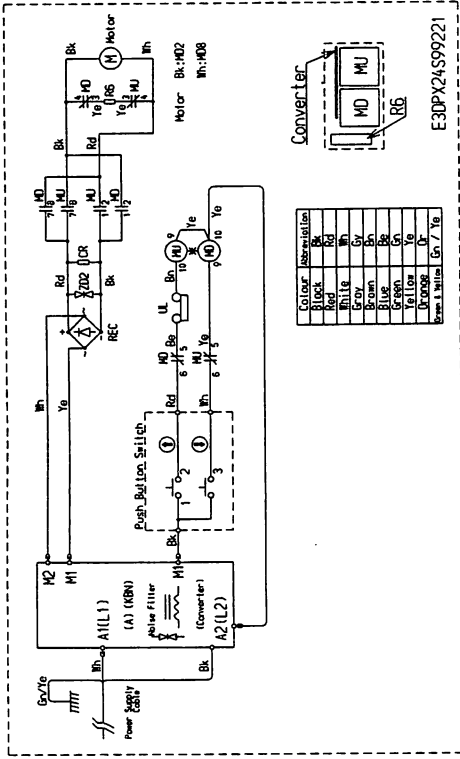

Motor output 600W
(Rated load 160kg, 240kg, 480kg)

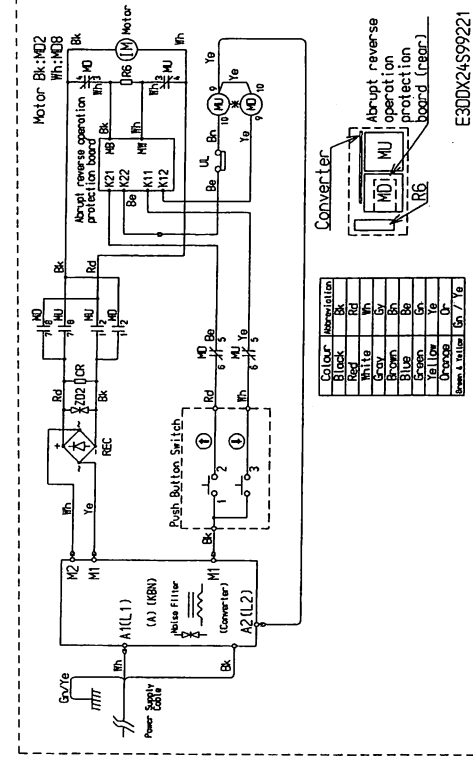

Motor output 600W
(Rated load 160kg, 240kg, 480kg)

(3) Low voltage control type (120V)

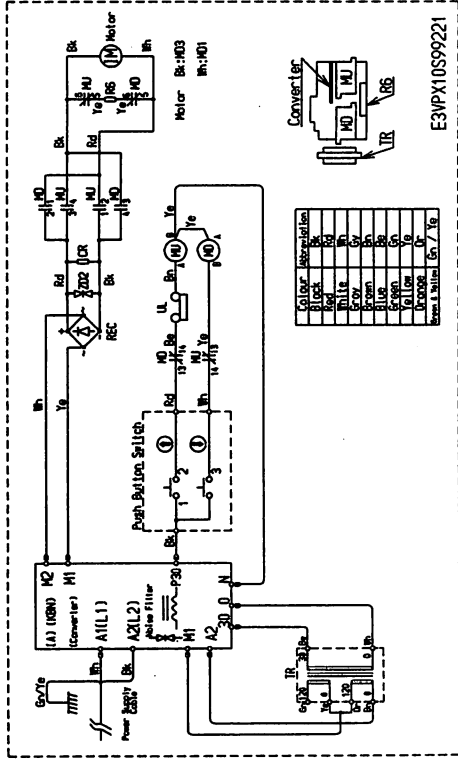

Motor output 300W
(Rated load 60kg, 100kg, 180kg)

(4) Low voltage control type (240V)

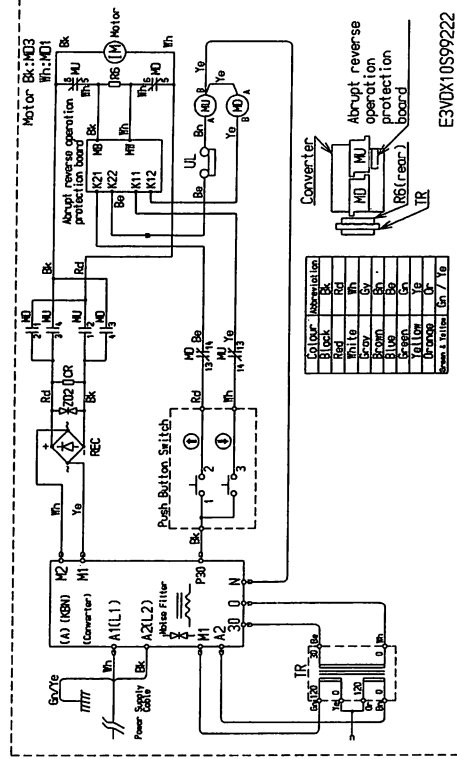

Motor output 300W
(Rated load 60kg, 100kg, 180kg)

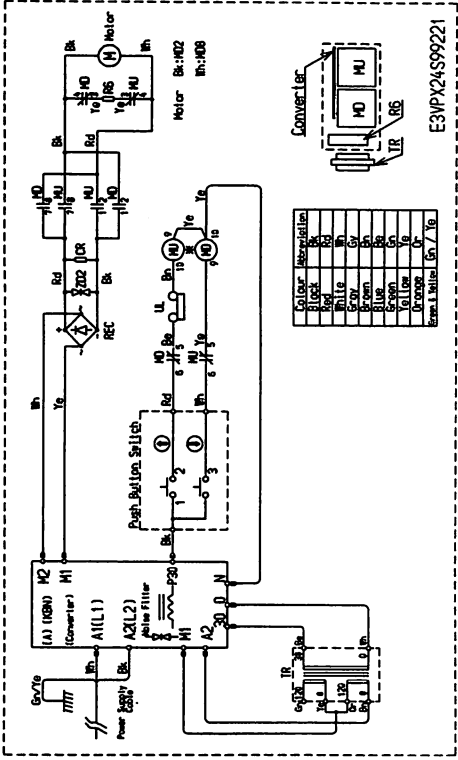

Motor output 600W
(Rated load 160kg, 240kg, 480kg)

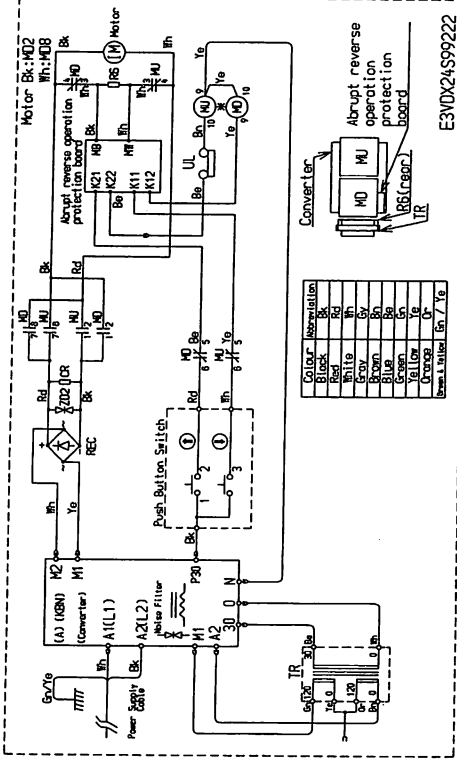

Motor output 600W
(Rated load 160kg, 240kg, 480kg)

7-2. Dual-speed Type and Dual-speed Cylinder Type

(1) Normal voltage control type (120V)

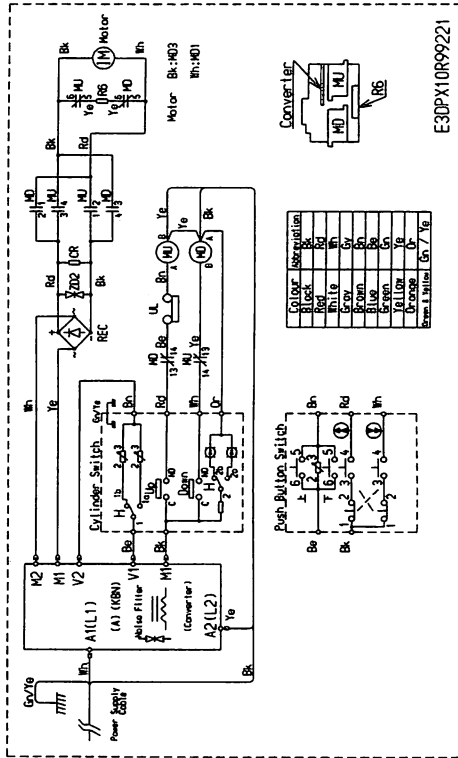

Motor output 300W
(Rated load 60kg, 100kg, 180kg)

(2) Normal voltage control type (240V)

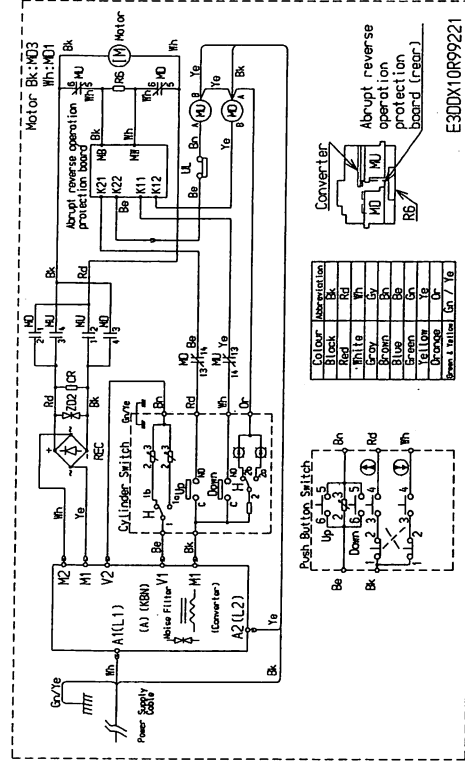

Motor output 300W
(Rated load 60kg, 100kg, 180kg)

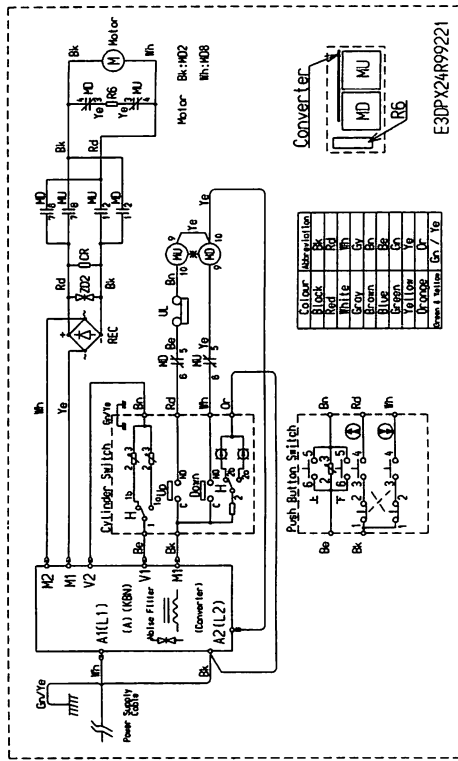

Motor output 600W
(Rated load 160kg, 240kg, 480kg)

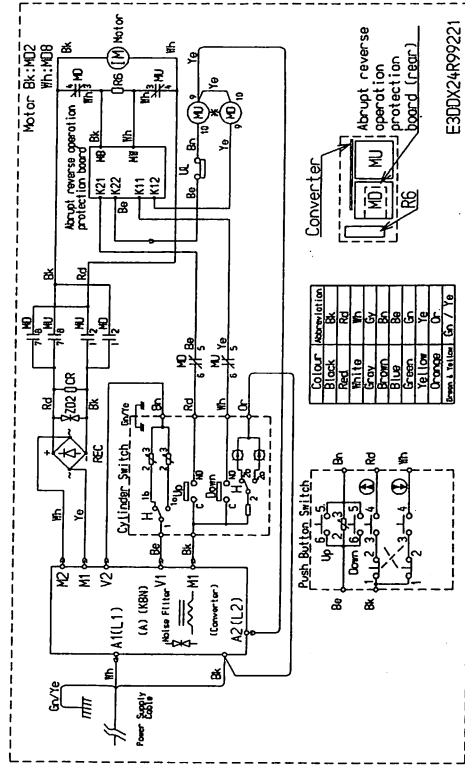

Motor output 600W
(Rated load 160kg, 240kg, 480kg)

(3) Low voltage control type (120V)

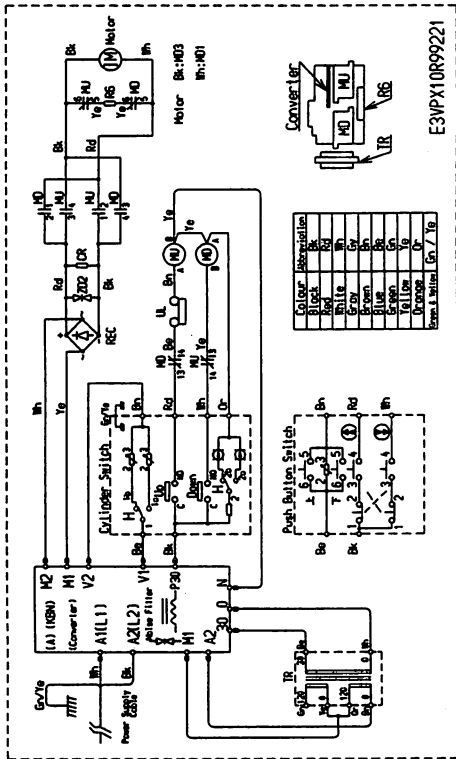

**Motor output 300W
(Rated load 60kg, 100kg, 180kg)**

(4) Low voltage control type (240V)

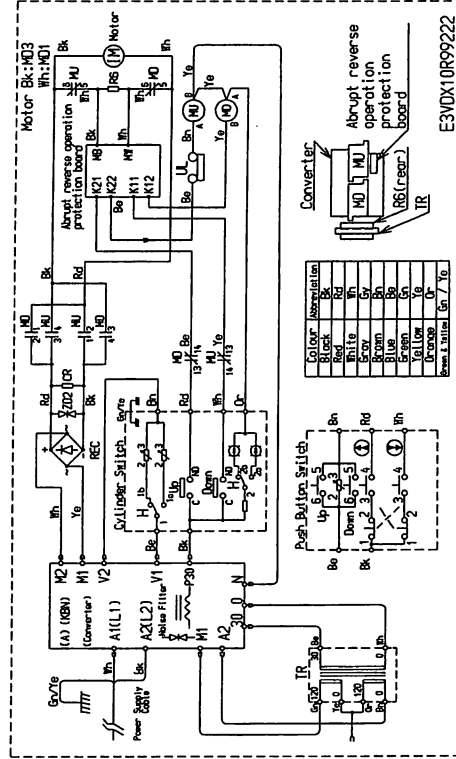

**Motor output 300W
(Rated load 60kg, 100kg, 180kg)**

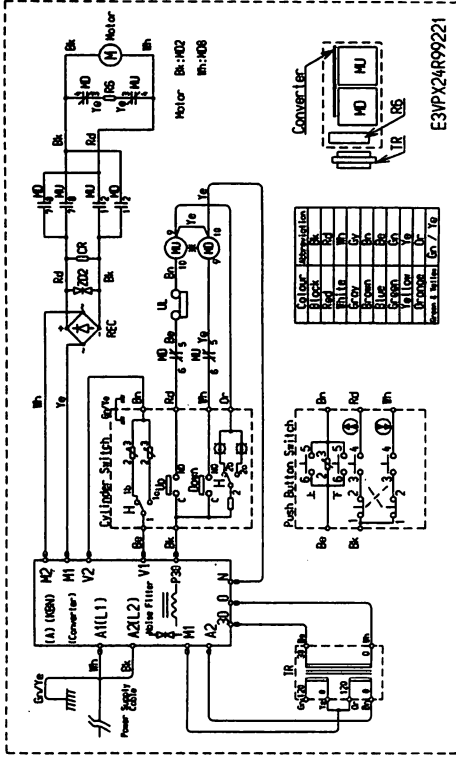

**Motor output 600W
(Rated load 160kg, 240kg, 480kg)**

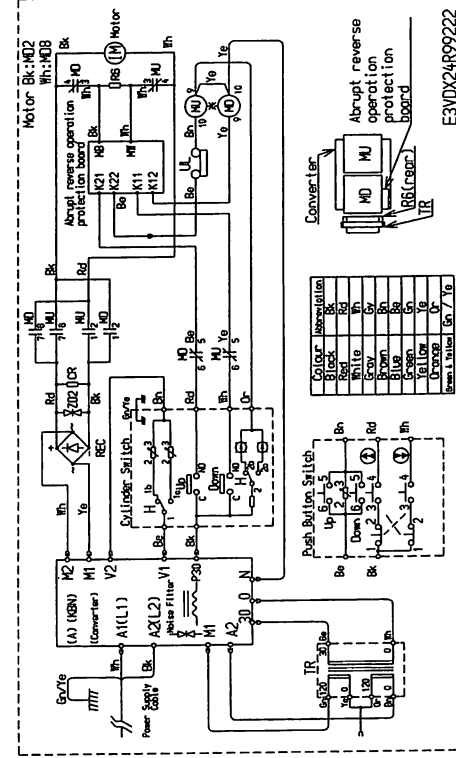

**Motor output 600W
(Rated load 160kg, 240kg, 480kg)**

8. TROUBLE-SHOOTING AND SOLUTIONS

When a trouble arises, remove cause referring to the following table.

Trouble	Condition		Cause	Solution
Both lifting and lowering are not possible.	* When the push button is pressed, a clicking sound is heard from the electric instruments unit.	* Fuse has burned out.	* Motor has been burned out due to too much use.	* Replace motor. * Use under rated conditions.
			* Abnormal voltage.	* Use under rated voltage.
		* Fuse is normal.	* Rectifier abnormality. * Wiring abnormality.	* Replace rectifier. * Normalize.
	* The push button works, but no clicking sound is heard from the electric instruments unit.	* Fuse is normal.	* Power cable/push-button cord has been disconnected.	* Replace the power cable/push-button cord.
			* Voltage drop.	* Use under rated voltage.
	Either lifting or lowering does not work.	* When the push button is operated, a clicking sound is heard from the electric instruments unit.	* Brush wear.	* Replace brush.
* Chain guide wear.			* Replace chain guide.	
* Overload (lifting impossible).			* Use within rated load.	
* The push button is operated but no clicking sound is heard from the electric instruments unit.		* Push-button cord defect or disconnection.	* Replace cord.	
Lifting/lowering speed is too slow.	* Speed is not only too slow but constant.	* Voltage drop.	* Use under the rated voltage.	
		* Deteriorated speed control function of controller.	* Replace with a normal one. * Replace control panel complete set.	
	* Motor stops with excessive slip under light load.	* Deteriorated clutch brake function.	* Replace the set of mechanical brake with friction clutch.	
	* When winding, a motor sound is heard but load lifting tends to stop in the middle.	* Overload.	* Use within rated load.	

Trouble	Condition	Cause	Solution
Brake slip-page.	* Braking distance is too long, even under no-load conditions.	* Motor has become demagnetized, owing to too frequent use.	* Replace with a normal one.
		* improper contact of electromagnetic contacts.	
		* Deteriorated resistor for dynamic braking.	
	* The load can not be held at the level when stopping operation.	* Improper gear oil use.	* Replace the specified gear oil.
	* Within rated load, lifting/lowering speed is slow.	* Deterioration of clutch brake.	* Replace the set of mechanical brake with friction clutch.
Oil leakage.	* Oil leakage from case joint and chain guide.	* Defective gear case packing/oil seal.	* Replace with a normal one.
		* Loosened assembly bolts.	* Fasten with normal torque.
	* Leakage from oil plug.	* Loosened oil plug.	* Fasten oil plug.
A clicking sound is heard from the load chain during lifting.	-	* Wear of load sheave.	* Replace with a normal one.
		* Wear of load chain.	
		* Rust on load chain.	
Electric shock.	-	* Accumulation of moisture/foreign matter on electrical instruments.	* Remove moisture/foreign substance.
		* Improper grounding.	* Secure correct grounding.

Ask your local Kito dealer to repair.

For maintenance, a fuse shown in the table is attached in the controller cover (the capacity/name plate side) as a spare.

Fuses for maintenance

Rated road [kg]	Rated power source Speed	Fuse capacity [A] × (Nos. per hoist) [pcs.]			
		120[V]		240[V]	
		Normal voltage operation		Low-voltage operation	
60	Single	10×(2)	5×(2)	10×(2)	5×(2)
	Dual	10×(2)	5×(2)		
80		0.1×(1)	0.1×(1)		
180					
160	Single	15×(2)	10×(2)	15×(2)	10×(2)
	Dual	15×(2)	10×(2)		
240		0.1×(1)	0.1×(1)		
480					

9. WARRANTY

Kito Corporation (“Kito”) extends the following warranty to the original purchaser (“Purchaser”) of new products manufactured by “Kito” (Kito’s Products).

- (1) “Kito” warrants that Kito’s Products, when shipped, shall be free from defects in workmanship and/or materials under normal use and service and “Kito” shall, at the election of “Kito”, repair or replace free of charge any parts or items which are proven to have said defects, provided that all claims for defects under this warranty shall be made in writing immediately upon discovery and, in any event, within one (1) year from the date of purchase of Kito’s Products by “Purchaser” and provided, further, that defective parts or items shall be kept for examination by “Kito” or its authorized agents or returned to Kito’s factory or authorized service center upon request by “Kito”.
- (2) “Kito” does not warrant components of products provided by other manufacturers. However to the extent possible, “Kito” will assign to “Purchaser” applicable warranties of such other manufacturers.
- (3) Except for the repair or replacement mentioned in (1) above which is “Kito”’s sole liability and purchaser’s exclusive remedy under this warranty, “Kito” shall not be responsible for any other claims arising out of the purchase and use of Kito’s Products, regardless of whether “Purchaser”’s claims are based on breach of contract, tort or other theories, including claims for any damages whether direct, indirect, incidental or consequential.
- (4) This warranty is conditional upon the installation, maintenance and use of Kito’s Products pursuant to the product manuals prepared in accordance with content instructions by “Kito”. This warranty shall not apply to Kito’s Products which have been subject to negligence, misuse, abuse, misapplication or any improper use or combination or improper fittings, alignment or maintenance.
- (5) “Kito” shall not be responsible for any loss or damage caused by transportation, prolonged or improper storage or normal wear and tear of Kito’s Products or for loss of operating time.
- (6) This warranty shall not apply to Kito’s Products which have been fitted with or repaired with parts, components or items not supplied or approved by “Kito” or which have been modified or altered.

THIS WARRANTY IS IN LIEU OF ALL OTHER WARRANTIES, EXPRESS OR IMPLIED, INCLUDING BUT NOT LIMITED TO ANY WARRANTY OF MERCHANTABILITY OR OF FITNESS FOR A PARTICULAR PURPOSE.

10. PARTS LIST

Exploded views and part names of the electric chain hoist are given in the following.

Note: When ordering replacement parts, please specify the following points :

1. Voltage
2. Capacity and lifting speed
3. Model number on name plate
4. Correct part names and numbers
5. Lineal length of push button cord or power supply cable

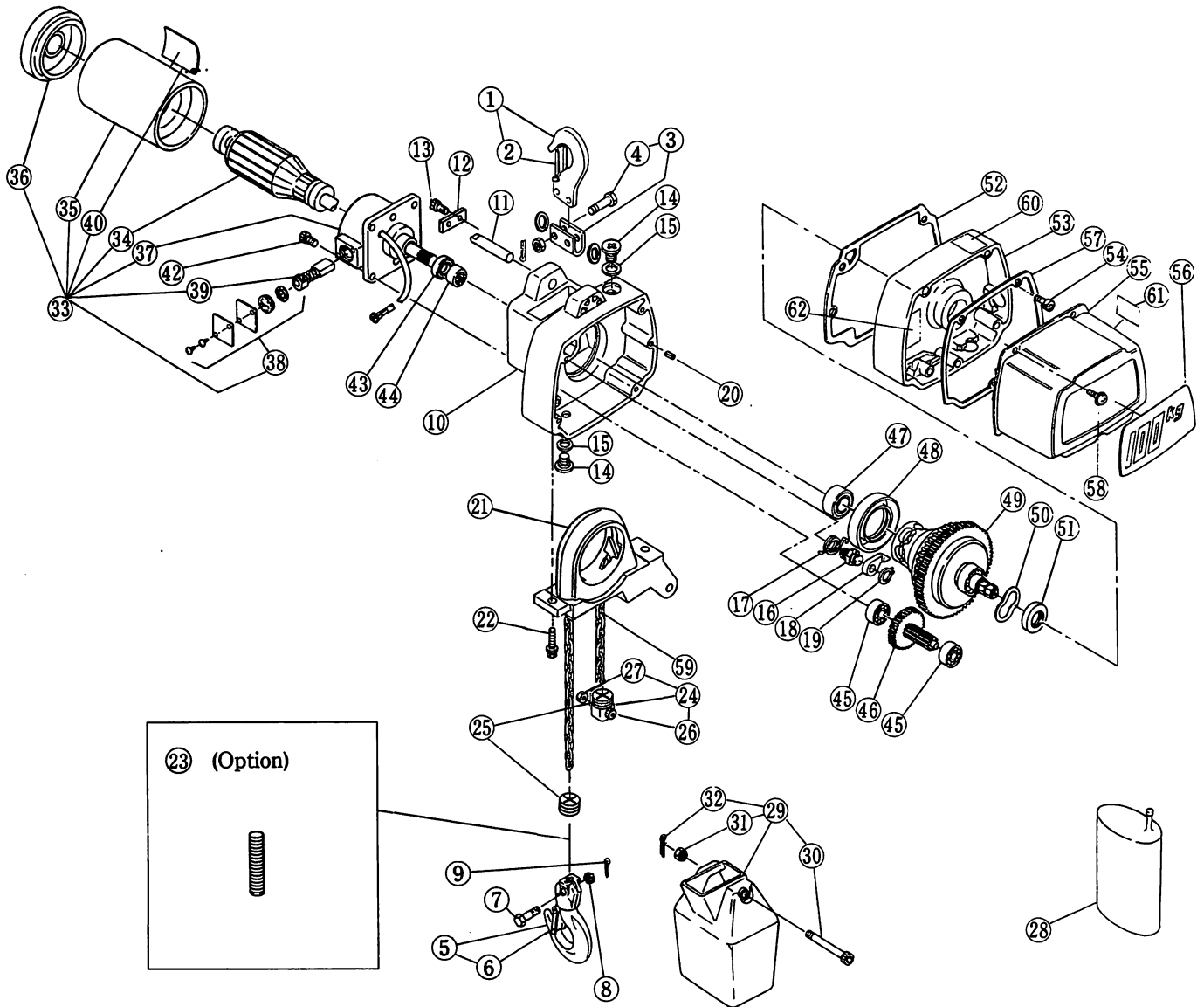

Fig. No.	Part No.	Part Name	Nos. Per Hoist	Capacity				
				60kg	100kg	180kg	160kg	240kg
①	E2D1001	Top hook assembly	1					
2	E2D1071T	Hook latch assembly T	1					
③	E2D1011	Top yoke complete set	1					
4	E2D5091	Top pin assembly	2					
⑤	E2D1021	Bottom hook complete set	1					
6	E2D1071B	Hook latch assembly B	1					
⑦	E2D 041	Chain pin	1					
⑧	E2D 049	Slotted nut	1					
⑨	E2D 096	Split pin	1					
⑩	E3D 101	Body	1					
⑪	E2D 117	Top pin E	1					
⑫	E2D 118	Shaft stopper	1		—————			
⑬	E2D 072	Socket bolt with spring washer	2		—————			
⑭	E2D 111	Oil plug	2					
⑮	E2D 112	Plug packing	2					
⑯	E2D 269	Pawl pin	1					
⑰	E2D 270	Pawl spring	1					
⑱	E2D 268	Pawl	1					
⑲	E2D 271	Snap ring	1					
⑳	E2D 114	Set pin	2					
㉑	E3D 401	Chain guide	1					
㉒	E2D 451	Socket bolt with spring washer	2					
㉓	E3D 421	Chain spring (option)	1					
㉔	E3D1045	Stopper complete set	1					
25	E3D 046	Cushion rubber	2					
26	E2D 086	Socket bolt with spring washer	1					
27	E2D 087	Lever nut	1					
㉘	E3D 901	Gear oil	1					
㉙	E2D1831	Chain container (3)	1					
	E2D1835	Chain container (6)	1					
30	E2D 854	Socket bolt BP	1					
31	E2D 853	U nut	1					
32	E2D 852	Split pin	1					
③③	E2D1501P	Motor complete set for 120V, 50/60Hz	1					
	E2D1501D	Motor complete set for 240V, 50/60Hz	1					
34	E2D5508P	Armature assembly for 120V, 50/60Hz	1					
	E2D5508D	Armature assembly for 240V, 50/60Hz	1					
35	E2D5507	Stator assembly	1					
36	E2D 509	Motor cover	1					
37	E2D 506	Motor flange	1					
38	E2D1510	Lid assembly	2					
39	E2D 502	Carbon brush	2					
40	E2D 802	Name plate M						

Fig. No.	Part No.	Part Name	Nos. Per Hoist	Capacity				
				60kg	100kg	180kg	160kg	240kg
④②	E2D 162	Socket bolt with spring washer	4	Note 1		Note 2	Note 1	Note 3
	E3D 451	Socket bolt with spring washer	4	Note 4		Note 5	Note 4	Note 6
④③	E2D 221	Oil seal	1					
④④	E2D 222	Needle roller bearing	1					
④⑤	E2D 231	Ball bearing	2					
④⑥	E2D1223	Gear # 2 assembly	1					
④⑦	E2D 238	Ball bearing	1					
④⑧	E2D 236	Oil seal	1					
④⑨	E2D5234	Friction clutch assembly (incl. Load sheave)	1					
⑤⑩	E2D 311	Set spring	1					
⑤①	E2D 239	Oil seal	1					
⑤②	E2D 125	Gear case packing	1					
⑤③	E2D 105	Gear case	1					
⑤④	E2D 152	Socket bolt with spring washer	4					
⑤⑤	E2D 104	Controller cover	1					
⑤⑥	E3D 801	Name plate B	1					
⑤⑦	E2D 109	Controller cover packing	1					
⑤⑧	E2D 151	Machine screw with spring washer	3					
⑤⑨	E2D 841	Load chain	1					
⑥⑩	E2D 865	Warning seal EO	1					
⑥①	E2D 866	Warning seal EE	1					
⑥②	E2D 867	Warning seal EF	1					

Note 1: Lot No before that of Note 4

Note 2: Lot No before that of Note 5

Note 3: Lot No before that of Note 6

Note 4: Lot No on & after 6ASY8681

Note 5: Lot No on & after 6ASY8680

Note 6: Lot No on & after 6ASY8312

When either of '10 Body' or '42 Socket bolt with spring washer' is ordered, please also the counterpart of it.

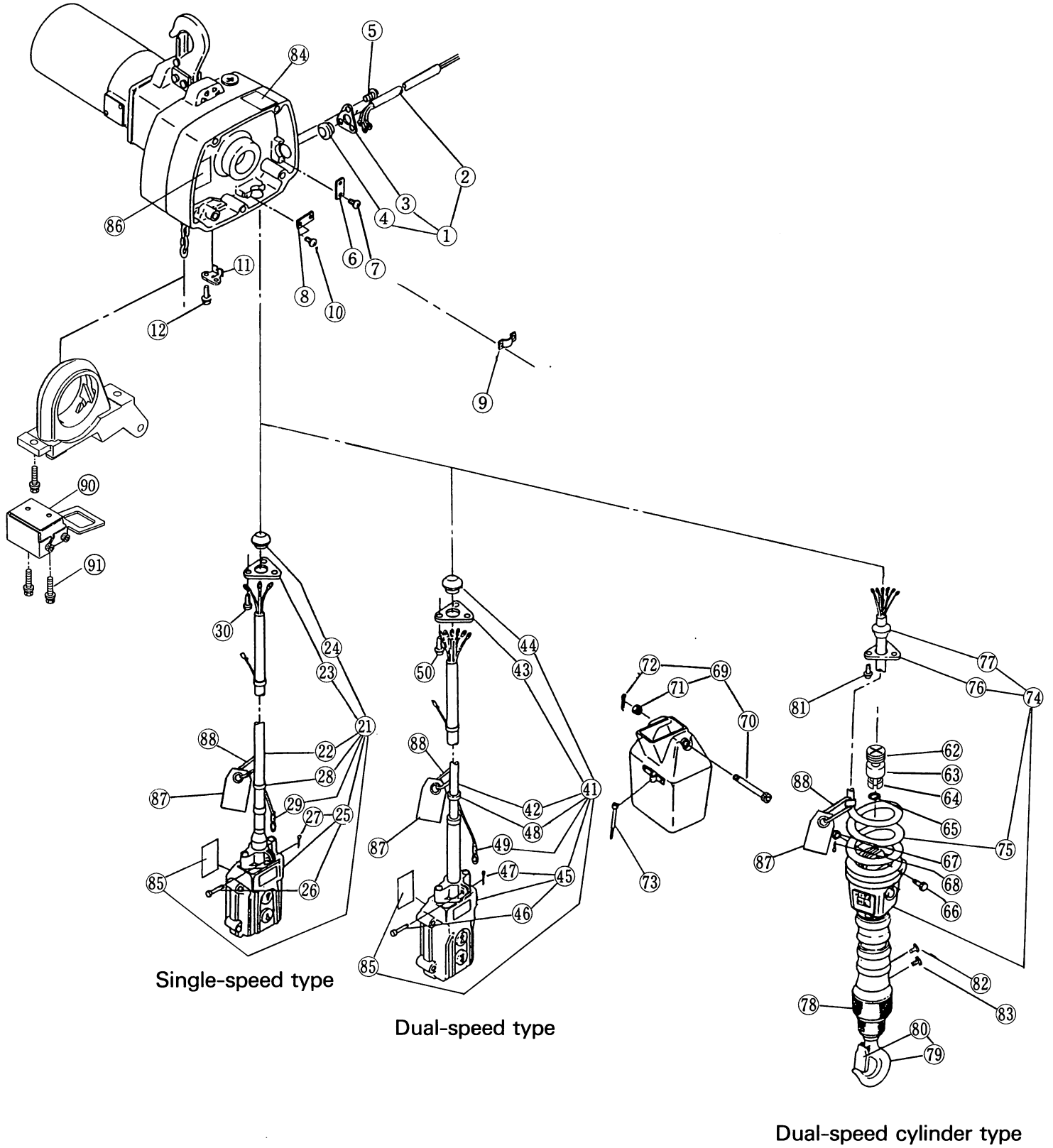

Fig. No.	Part No.	Part Name	Nos. Per Hoist	Capacity				
				60kg	100kg	180kg	160kg	240kg
①	E2D1521	Power supply cable 3C complete set	1					
2	E2D 521	Power supply cable 3C	1					
3	E2D 537	Cable holder C	1					
4	E2D 524	Cable packing C8	1					
⑤	E2D 555	Machine screw with spring washer	3					
⑥	E2D 541	Cable clamp E8	1					
⑦	E2D 551	Machine screw with spring washer	2					
⑧	E2D 541	Cable clamp E8 (Single speed)	1					
⑨	E2D 542	Cable clamp E12 (Dual/Cylinder)	1					
⑩	E2D 551	Machine screw with spring washer	2					
⑪	E2D 543	Cable support L	1					
⑫	E D 552	Machine screw with spring washer	2					
⑳	E2D1607	Push button cord 3C complete set	1					
22	E2D 607	Push button cord 3C	1					
23	E2D 537	Cable holder C	1					
24	E2D 524	Cable packing C8	1					
25	E2D1615	Push button switch S assembly	1					
26	—	Cord chain pin	1					
27	—	Split pin	1					
28	E2D 640	Lock-belt	3					
29	—	Fixing sleeve	1					
⑳	E2D 555	Machine screw with spring washer	3					
㉑	E2D1607*	Push button cord 6C complete set	1					
42	E2D 607	Push button cord 6C	1					
43	E2D 537	Cable holder C	1					
44	E2D 525	Cable packing C12	1					
45	E2D1615	Push button switch D assembly	1					
46	—	Cord chain pin	1					
47	—	Split pin	1					
48	E2D 640	Lock-belt	3					
49	—	Fixing sleeve	1					
⑤⑩	E2D 555	Machine screw with spring washer	3					
⑥②	E3D 046	Cushion rubber	2					
⑥③	E2D 044	Stopper collar	1					
⑥④	E2D 045	Stopper	2					
⑥⑤	—	Snap ring	1					

※This complete set differs depending on power voltage and/or control voltage.

Fig. No.	Part No.	Part Name	Nos. Per Hoist	Capacity				
				60kg	100kg	180kg	160kg	240kg
66	E2D 041	Chain pin	1					
67	E2D 049	Slotted nut	1					
68	E2D 096	Split pin	1					
⑥9	E2D1831	Chain container (3m lift for cylinder type)	1					
70	E2D 854	Socket bolt BP	1					
71	E2D 853	U nut	1					
72	E2D 852	Split pin	1					
⑦3	E2D 861	Clamp	1					
⑦4*	E2D1607	Push button cord 7C complete set	1					
75	———	Push button cord 7C assembly	1					
76	E2D 537	Cable holder C	1					
77	E2D 525	Cable packing C12	1					
⑦8	E2D5041	Detachable fitting E	1					
⑦9	E2D1002	Detachable hook assembly	1					
80	E2D1071	Hook latch assembly	1					
⑧1	E2D 555	Machine screw with spring washer	3					
⑧2	———	Flat head screw	1					
⑧3	———	Flat head screw	1					
⑧4	E2D 865	Warning seal EO	1					
⑧5	E2D 866	Warning seal EE	1					
⑧6	E2D 867	Warning seal EF	1					
⑧7	E2D 931	Warning tag LD	1					
⑧8	E2D 870	Chain stopper link	1					
⑨0	E3D1411	Limit switch assembly	1					
	E3D1411-C	Limit switch assembly ※1	1					
⑨1	E3D 422	Socket bolt with spring washer	2					

※ This complete set differs depending on power voltage and/or control voltage.

※ 1: For 'Control panel complete set' equipped with reverse-operation protection board.

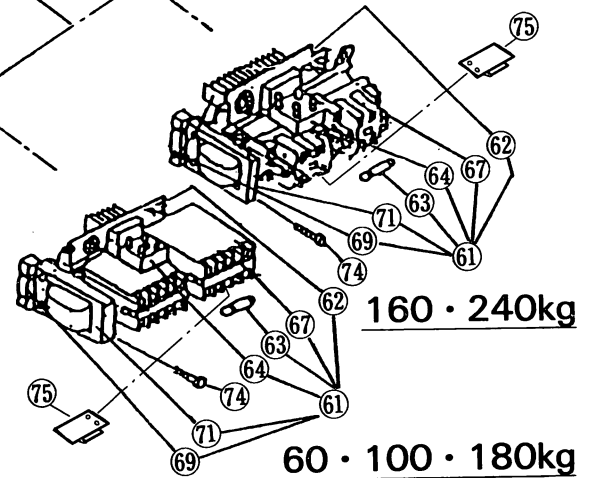
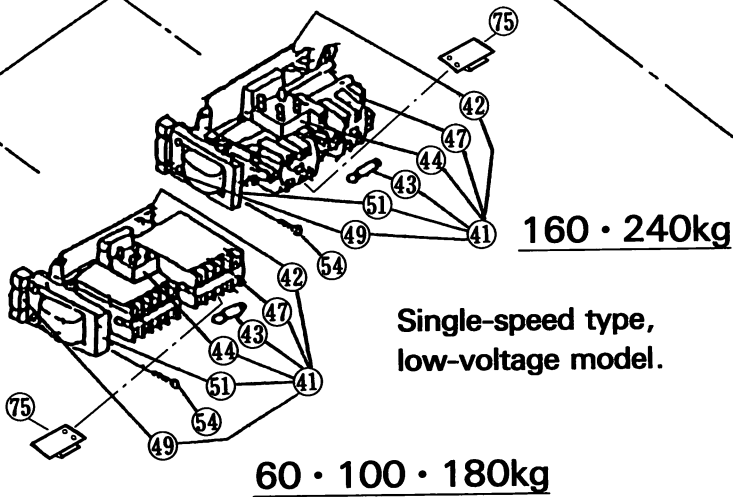
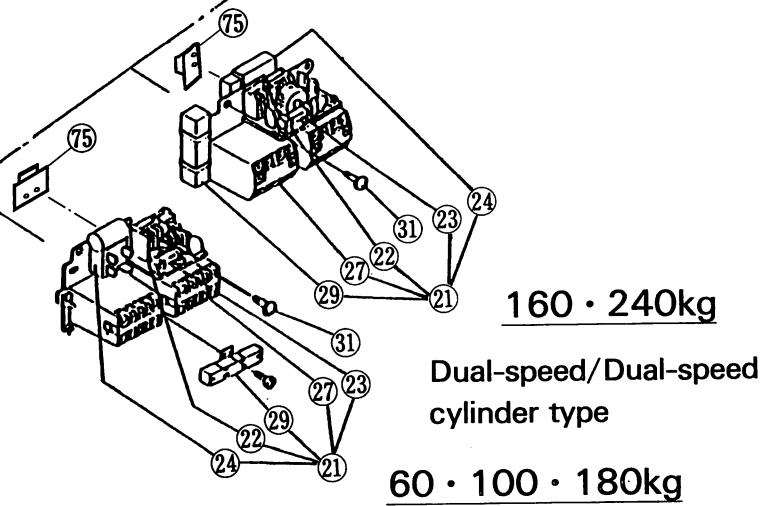
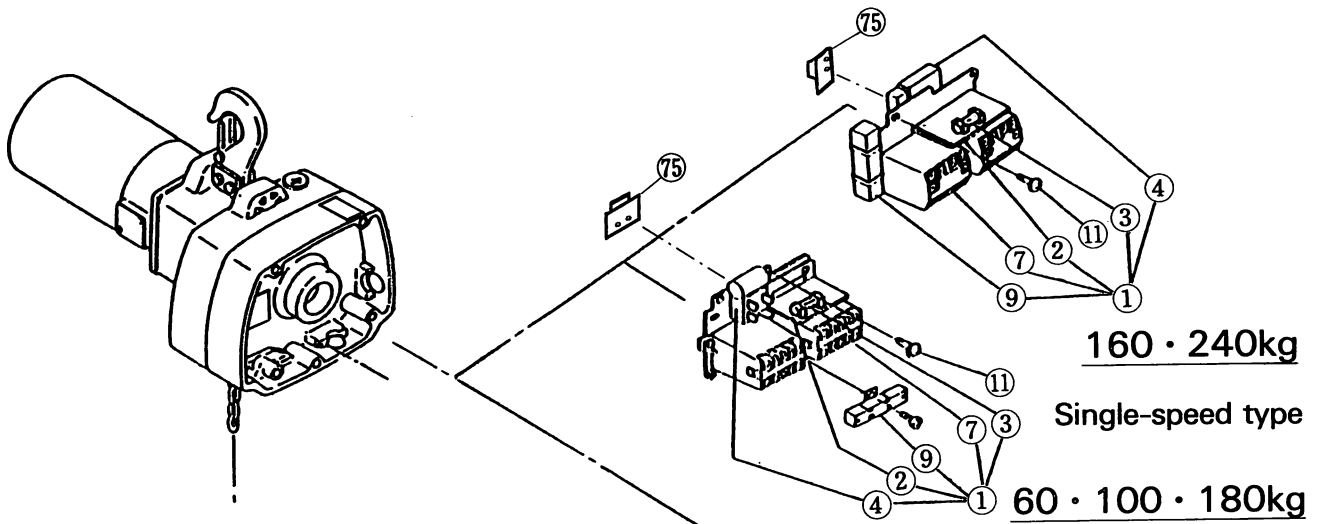

Fig. No.	Part No.	Part Name	Nos. Per Hoist	Capacity				
				60kg	100kg	180kg	160kg	240kg
①	E3DC1601	Control panel complete set	1					
	E3DC1601-C	Control panel complete set *1	1					
2	E2D 616	Converter assembly	1					
3	E2D 664A	Fuse set	※					
4	E2D 622	Silicone stack assembly	1					
5	E2D 667	Machine screw with spring washer	2	For converter				
6	E2D 663	Machine screw with spring washer	1	For silicone stack				
7	E2D 617	Electromagnetic contactor	2					
		Electromagnetic contactor complete set	1					
8	E2D 661	Machine screw with spring washer	4	For contactor				
	—	Machine screw with spring washer	4				For base	
9	E2D 619	Resistor	1					
10	E2D 665	Machine screw with spring washer	1	For resistor				
75	E3D 371	Abrupt reverse operation protection board *1	1					
⑪	E2D 651	Socket bolt with spring washer	3					
			4					
⑫	E3DC1601	Control panel complete set	1					
	E3DC1601-C	Control panel complete set *1	1					
22	E2D 616	Converter assembly	1					
23	E2D 664A	Fuse set	※					
24	E2D 622	Silicone stack assembly	1					
25	E2D 667	Machine screw with spring washer	2	For converter				
26	E2D 663	Machine screw with spring washer	1	For silicone stack				
27	E2D 617	Electromagnetic contactor	2					
		Electromagnetic contactor complete set	1					
28	E2D 661	Machine screw with spring washer	4	For contactor				
	—	Machine screw with spring washer	4				For base	
29	E2D 619	Resistor	1					
30	E2D 665	Machine screw with spring washer	1	For resistor				
75	E3D 371	Abrupt reverse operation protection board *1	1					
⑬	E2D 651	Socket bolt with spring washer	3					
			4					
⑭	E3DC1601	Control panel complete set	1					
	E3DC1601-C	Control panel complete set *1	1					
42	E2D 616L	Converter assembly	1					
43	E2D 664A	Fuse set	※					
44	E2D 622	Silicone stack assembly	1					
45	E2D 667	Machine screw with spring washer	4	For converter				
46	E2D 663	Machine screw with spring washer	1	For silicone stack				
47	E2D 617L	Electromagnetic contactor	2					
		Electromagnetic contactor complete set	1					
48	E2D 661	Machine screw with spring washer	4	For contactor				
	—	Machine screw with spring washer	4				For base	
49	E2D 619	Resistor	1					
50	E2D 665	Machine screw with spring washer	1	For resistor				
51	E2D 702L	Transformer	1					
52	E2D 670L	Nut	2	For transformer				
53	E2D 671L	Machine screw with spring washer	2	For transformer				
75	E3D 371	Abrupt reverse operation protection board *2	1					

※ 1: Equipped with reverse-operation protection board.

※ 2: This part is only for AC240V type.

Fig. No.	Part No.	Part Name	Nos. Per Hoist	Capacity				
				60kg	100kg	180kg	160kg	240kg
⑤4	E2D 651	Socket bolt with spring washer	3					
			4					
⑥1	E3DC1601	Control panel complete set	1					
	E3DC1601-C	Control panel complete set *1	1					
62	E2D 616L	Converter assembly	1					
63	E2D 664A	Fuse set	*					
64	E2D 622	Silicone stack assembly	1					
65	E2D 667	Machine screw with spring washer	4	For converter				
66	E2D 663	Machine screw with spring washer	1	For silicone stack				
67	E2D 617L	Electromagnetic contactor	2					
		Electromagnetic contactor complete set	1					
68	E2D 661	Machine screw with spring washer	4	For contactor				
	——	Machine screw with spring washer	4				For base	
69	E2D 619	Resistor	1					
70	E2D 665	Machine screw with spring washer	1	For resistor				
71	E2D 702L	Transformer	1					
72	E2D 670L	Nut	2	For transformer				
73	E2D 671L	Machine screw with spring washer	2	For transformer				
75	E3D 371	Abrupt reverse operation protection board *2	1					
⑦4	E2D 651	Socket bolt with spring washer	3					
			4					

Part which part No. is suffixed with L is only for low voltage control type hoist.

* Contents of fuse set are tabulated in page 33.

* 1: Equipped with reverse-operation protection board.

* 2: This part is only for AC240V type.

Exploded views and part names of the trolley are shown below.

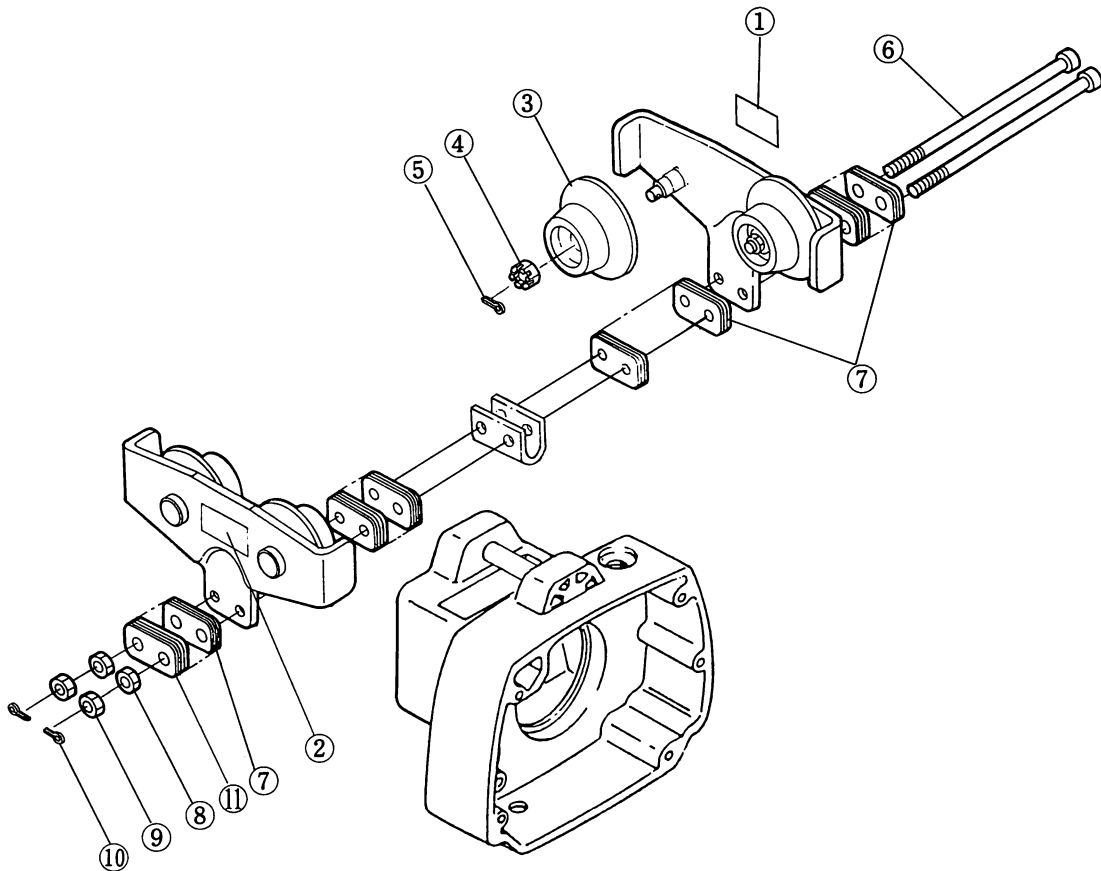

Fig. No.	Part No.	Part Name	Nos. Per Trolley	Capacity
				250kg
①	T1H 801	Name plate C	1	
②	T1H 800	Name plate B	1	
③	T1H5102	Track wheel assembly	4	
④	T1H 152	Slotted nut	4	
⑤	T1H 153	Split pin	4	
⑥	T1H 115	Socket bolt	2	
⑦	T1H 116	Adjusting spacer	34	
⑧	T1H 157	Nut	2	
⑨	T1H 155	U nut	2	
⑩	T1H 156	Split pin	2	
⑪	T1H117	Adjusting spacer B	2	

PARTS LIST (480kg)

Exploded views and part names of the electric chain hoist are given in the following.

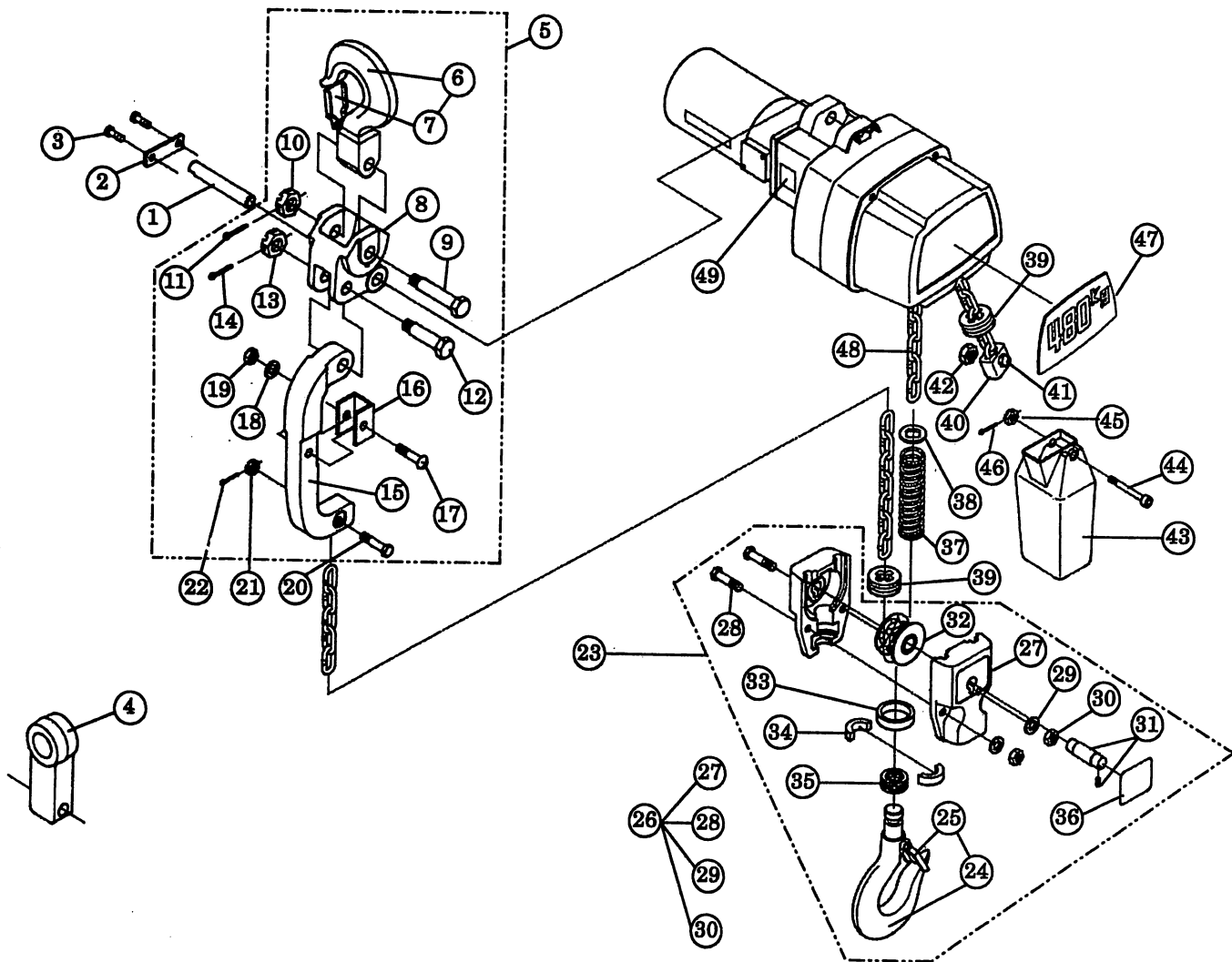

Fig. No.	Part No.	Part Name	Nos. Per Hoist	Supplement
①	E2D-117	Top pin E	1	
②	E2D-118	Shaft stopper	1	
③	E3D-155	Socket bolt with spring washer	2	
④	T7PB-004	Suspender PB	1	PT Connect
	T7GB-004	Suspender GB	1	GT Connect
⑤	E3D-1470	Connection yoke complete set	1	
6	E3D-460	Top hook assembly	1	
7	E3D-461	Hook latch assembly	1	
8	E3D-470	Connection yoke	1	
9	E3D-471	Yoke bolt	1	
10	E3D-472	Slotted nut	1	
11	E3D-473	Split pin	1	
12	E3D-581	Connection bolt	1	
13	E3D-582	Slotted nut	1	

Fig. No.	Part No.	Part Name	Nos. Per Hoist	Supplement
14	E3D-583	Split pin	1	
15	E3D-580	Joint yoke	1	
16	E3D-592	Protection pad	2	
17	E3D-593	Truss head machine screw	1	
18	E3D-594	Washer	1	
19	E3D-595	U nut	1	
20	E1D-041	Chain pin	1	
21	E1D-049	Slotted nut	1	
22	E1D-096	Split pin	1	
㉓	E3D-1480	Bottom hook complete set	1	
24	E3D-480	Bottom hook assembly	1	
25	E3D-491	Hook latch assembly	1	
26	E3D-2485	Bottom hook assembly	1	
27	E3D-485	Bottom yoke	2	
28	E3D-496	Bolt	2	
29	E3D-498	Spring lock washer	2	
30	E3D-497	Nut	2	
31	E3D-6489	Bottom shaft assembly	1	
32	E3D-6487	Idle sheave assembly	1	
33	E3D-482	Thrust collar A	1	
34	E3D-483	Hook stopper	2	
35	E3D-481	Thrust bearing	1	
36	E3D-597	Name plate C	1	
㉗	E3D-590	Chain spring	1	
㉘	E3D-591	Washer	1	
㉙	E3D-046	Cushion rubber	2	
㉚	E3D-1045	Stoper complete set	1	
41	E2D-086	Socket bolt with spring washer	1	
42	E2D-087	Lever nut	1	
㉛	E2D-1835	Chain container (6)	1	Lift : 3m
	E2D-1833	Chain container (15)	1	Lift : 3.1~7.5m
	E2D-1834	Chain container (30)	1	Lift : 7.6~15m
44	E2D-854	Socket bolt BP	1	
45	E2D-853	U nut	1	
46	E2D-852	Split pin	1	
㉜	E2D-801	Name plate B	1	
㉝	E2D-841	Load chain	1	
㉞	E3D-599	Warning seal E (Finger protection)	1	

KITO

URL. <http://www.kito.co.jp>